

# WFL: Laser fork sensors

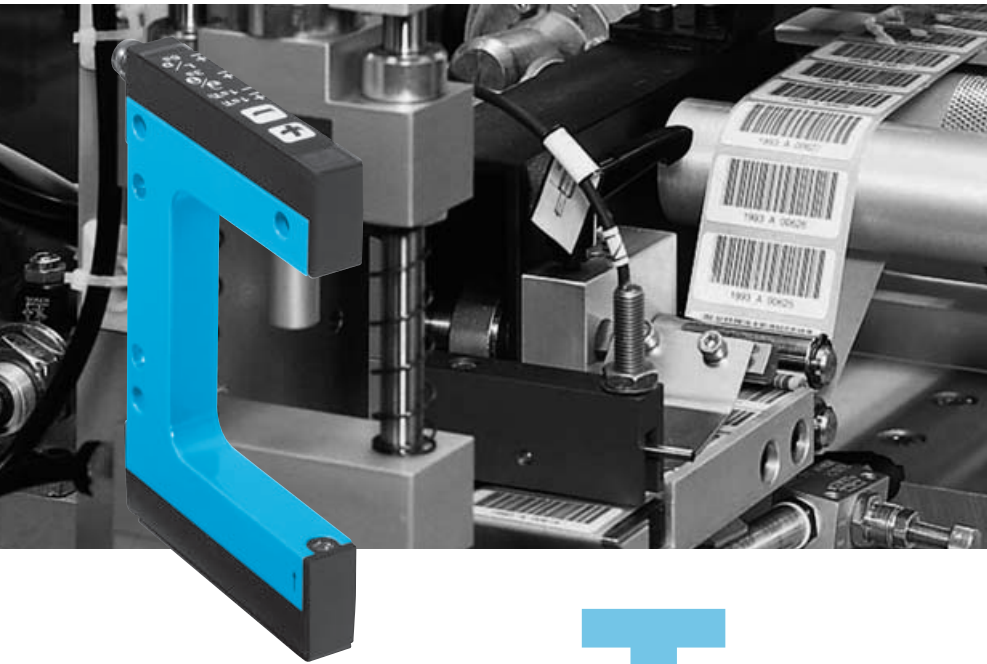

A complete range of 21 sensors with the following features is available:

- fork widths between 2 and 120 mm, fork depths of 40, 60 and 95 mm,
- simple and quick adjustment via Teach-in,
- switching output PNP and NPN,
- L/D adjustable via button,
- rugged metal housing with glass optics,
- shortest response time,
- very high resolution.



**T**he prime features of the laser fork sensor family are very high speed response time and also an extremely accurate focused laser beam. Sender and receiver are fitted into the same housing, thereby operating on the through-beam sensor principle. This allows and guarantees the highest positional accuracy.

Due to the extremely fast response times and very high resolution, the sensors are particularly suitable for detecting very small objects, such as needles. Additionally, they can be used for the detection of transparent objects.

Stocked, Distributed, and Supported by

**SENSORS**  
INCORPORATED

507 Kelsey Street • Delano, MN 55328  
Phone 763-972-1040 Fax 763-972-1041  
Toll Free 888-920-0939  
Sensorsincorporated.com

**SICK**

**Fork width**  
2 ... 120 mm

Fork sensors

- Very high resolution
- Simple setting using 2-point Teach-in
- Rugged aluminium housing
- High switching frequency for accurate positioning
- Precise and thin laser spot

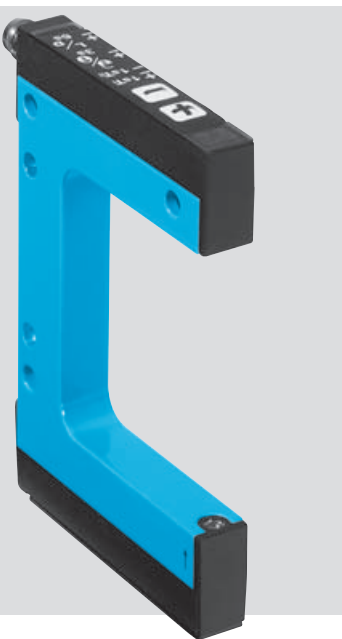

**Dimensional drawing**

All types

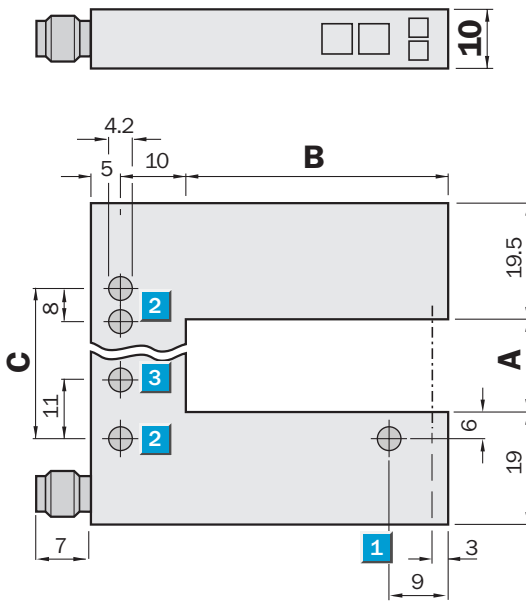

**Adjustments possible**

All types

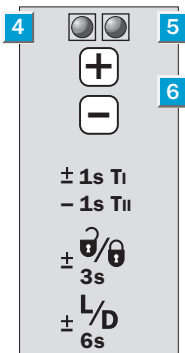

- 1 Optical axis
- 2 Mounting holes, Ø 4.2 mm
- 3 WFL50/80/120 only
- 4 Function indicator (red)
- 5 Function indicator (yellow), switching output
- 6 "+"/"- buttons and function button

**Dimensions**

Dimensions (mm)	A Fork width	B Fork depth	C
WFL2	2	42/59/95	14
WFL5	5	42/59/95	14
WFL15	15	42/59/95	27
WFL30	30	42/59/95	42
WFL50	50	42/59/95	51
WFL80	80	42/59/95	81
WFL120	120	42/59/95	121

CE CDRH

Laser class 1

**Accessories**  
Cables and connectors

**Connection types**

All types

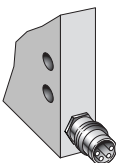

4-pin, M8

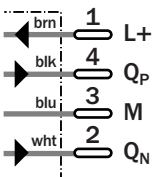

Technical data		WFL	2-XX <sup>1)</sup>	5-XX <sup>1)</sup>	15-XX <sup>1)</sup>	30-XX <sup>1)</sup>	50-XX <sup>1)</sup>	80-XX <sup>1)</sup>	120-XX <sup>1)</sup>			
			B416	B416	B416	B416	B416	B416	B416			
<b>Fork width</b>	2 mm											
	5 mm											
	15 mm											
	30 mm											
	50 mm											
	80 mm											
	120 mm											
<b>Fork depth</b>	40, 60 or 95 mm											
<b>Light source</b>	Laser, modulated, 670 nm, class 1											
<b>Minimum detectable object size</b>	0.05 mm											
<b>Supply voltage <math>V_S</math></b>	10 ... 30 V DC <sup>2)</sup>											
Current consumption <sup>3)</sup>	40 mA											
Residual ripple <sup>4)</sup>	< 10 %											
<b>Switching output</b>	PNP and NPN											
	Light/dark adjustable via button											
Signal voltage	PNP	HIGH = $V_S - (< 2 V)$ /LOW = 0 V										
	NPN	HIGH = $V_S$ /LOW = < 2 V										
Output current $I_A$	100 mA											
Stability of response time <sup>5)</sup>	$\pm 20 \mu s$											
Response time <sup>5)</sup> , switching frequency <sup>6)</sup>	Max. 100 $\mu s$ ; 10,000/s											
Teach-in via button												
Initialisation time	100 ms											
<b>Ambient light safety</b>	Incandescent lamp	5,000 Lux										
	Sunlight	10,000 Lux										
<b>VDE protection class<sup>7)</sup></b>												
<b>Enclosure rating</b>	IP 65											
<b>Circuit protection<sup>8)</sup></b>	A, B, C											
<b>Ambient temperature<sup>9)</sup></b>	Operation	-20 °C ... +50 °C										
	Storage	-30 °C ... +80 °C										
<b>Housing</b>	Aluminium											
<b>Weight</b>	Approx. 36 g to 160 g <sup>10)</sup>											

1) XX = Fork depth (E.g. 40 = fork depth equivalent to 40 mm)  
 2) Limit values, reverse-polarity protected  
 3) Without load

4) May not exceed or fall short of  $V_S$  tolerances  
 5) Signal transit time with resistive load  
 6) With light/dark ratio 1:1; no time delay  
 7) Reference voltage 50 V DC

8) A =  $V_S$  connections reverse-polarity protected  
 B = Outputs short-circuit protected  
 C = Interference pulse suppression  
 9) Do not bend below 0 °C

10) Depending on fork width

**Truth table**

Switching type	Light-switching (Q)		Dark-switching ( $\bar{Q}$ )	
	Yes	No	Yes	No
<b>Light path free</b>	Yes	No	Yes	No
<b>PNP/NPN output</b>	HIGH	LOW	LOW	HIGH
<b>Function indicator (yellow)</b>	On	Off	Off	On

**Order information**

Fork depth 40 mm		Fork depth 60 mm		Fork depth 95 mm	
Type	Order no.	Type	Order no.	Type	Order no.
WFL2-40B416	6036821	WFL2-60B416	6036828	WFL2-95B416	6036835
WFL5-40B416	6036822	WFL5-60B416	6036829	WFL5-95B416	6036836
WFL15-40B416	6036823	WFL15-60B416	6036830	WFL15-95B416	6036837
WFL30-40B416	6036824	WFL30-60B416	6036831	WFL30-95B416	6036838
WFL50-40B416	6036825	WFL50-60B416	6036832	WFL50-95B416	6036839
WFL80-40B416	6036826	WFL80-60B416	6036833	WFL80-95B416	6036840
WFL120-40B416	6036827	WFL120-60B416	6036834	WFL120-95B416	6036841

## Teach-in: adjusting the switching threshold

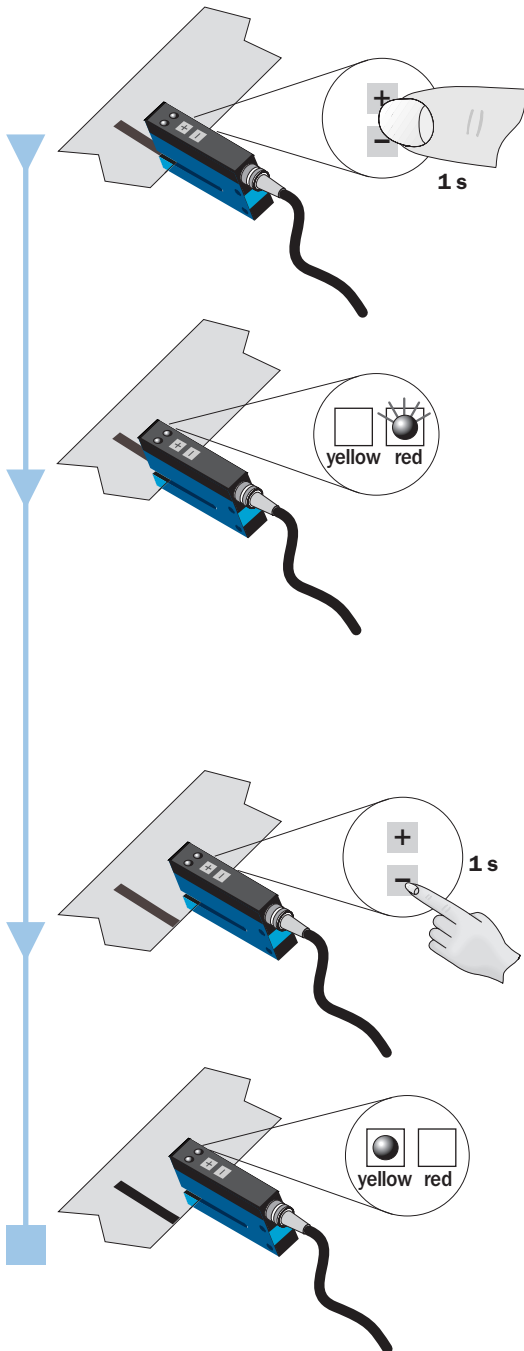

- The material speed during Teach-in must equal zero (machine stationary).

### 1st operation

- To enter Teach Mode push both buttons (“+” and “-”) for 1 second (no object).
- After the first Teach-in operation, the red function indicator flashes slowly and signals that the second Teach-in operation must now be initiated.

### 2nd operation

- Briefly operate the “-” button (on carrier material or without scanned object).
- After the second Teach-in operation, the red function indicator extinguishes.
- The Teach-in operation was unsuccessful if the red function indicator flashes.

### Notes

- **+** Following completion of the Teach-in operation, the switching threshold can be further adjusted by the “+” or “-” button at any time. For slower adjustment, press the “+” or “-” button once. For faster adjustment, the finger remains on the “+” or “-” button.
- **± 0/0** By simultaneously pressing the “+” and “-” buttons (3 seconds), the unit can be locked against unintentional adjustment.
- **± L/D** By simultaneously pressing the “+” and “-” buttons (6 seconds), the switching function (light/dark) can be inverted. Default setting: light switching.

Dimensional drawings and order information

SENSICK screw-in system M8, 4-pin, enclosure rating IP 67

Female connector M8, 4-pin, straight

Type	Order no.
DOS-0804-G	6009974

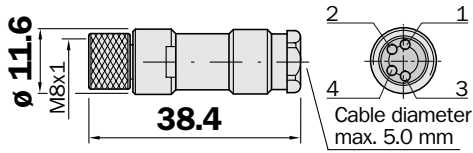

Female connector M8, 4-pin, right angle

Type	Order no.
DOS-0804-W	6009975

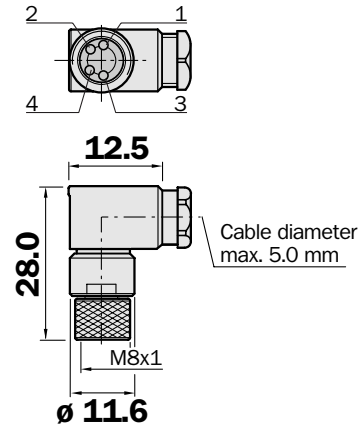

Female connector M8, 4-pin, straight

Cable diameter 5 mm, 4 x 0.25 mm<sup>2</sup>, sheath PVC

Type	Order no.	Cable length
DOL-0804-G02M	6009870	2 m
DOL-0804-G05M	6009872	5 m
DOL-0804-G10M	6010754	10 m

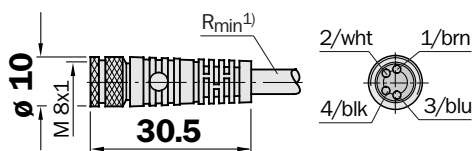

Female connector M8, 4-pin, right angle

Cable diameter 5 mm, 4 x 0.25 mm<sup>2</sup>, sheath PVC

Type	Order no.	Cable length
DOL-0804-W02M	6009871	2 m
DOL-0804-W05M	6009873	5 m
DOL-0804-W10M	6010755	10 m

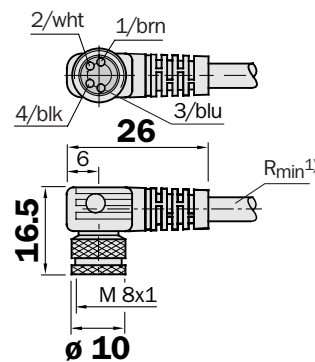

1) Minimum bend radius in dynamic use  
 $R_{min} = 20 \times \text{cable diameter}$

**Australia**

Phone +61 3 9497 4100  
1800 33 48 02 – tollfree  
E-Mail sales@sick.com.au

**Belgium/Luxembourg**

Phone +32 (0)2 466 55 66  
E-Mail info@sick.be

**Brasil**

Phone +55 11 3215-4900  
E-Mail sac@sick.com.br

**Ceská Republika**

Phone +420 2 57 91 18 50  
E-Mail sick@sick.cz

**China**

Phone +852-2763 6966  
E-Mail ghk@sick.com.hk

**Danmark**

Phone +45 45 82 64 00  
E-Mail sick@sick.dk

**Deutschland**

Phone +49 211 5301-250  
E-Mail info@sick.de

**España**

Phone +34 93 480 31 00  
E-Mail info@sick.es

**France**

Phone +33 1 64 62 35 00  
E-Mail info@sick.fr

**Great Britain**

Phone +44 (0)1727 831121  
E-Mail info@sick.co.uk

**India**

Phone +91-22-4033 8333  
E-Mail info@sick-india.com

**Israel**

Phone +972-4-999-0590  
E-Mail info@sick-sensors.com

**Italia**

Phone +39 02 27 43 41  
E-Mail info@sick.it

**Japan**

Phone +81 (0)3 3358 1341  
E-Mail support@sick.jp

**Nederlands**

Phone +31 (0)30 229 25 44  
E-Mail info@sick.nl

**Norge**

Phone +47 67 81 50 00  
E-Mail austefjord@sick.no

**Österreich**

Phone +43 (0)22 36 62 28 8-0  
E-Mail office@sick.at

**Polska**

Phone +48 22 837 40 50  
E-Mail info@sick.pl

**Republic of Korea**

Phone +82-2 786 6321/4  
E-Mail kang@sickkorea.net

**Republika Slovenija**

Phone +386 (0)1-47 69 990  
E-Mail office@sick.si

**România**

Phone +40 356 171 120  
E-Mail office@sick.ro

**Russia**

Phone +7 495 775 05 34  
E-Mail info@sick-automation.ru

**Schweiz**

Phone +41 41 619 29 39  
E-Mail contact@sick.ch

**Singapore**

Phone +65 6744 3732  
E-Mail admin@sicksgp.com.sg

**Suomi**

Phone +358-9-25 15 800  
E-Mail sick@sick.fi

**Sverige**

Phone +46 10 110 10 00  
E-Mail info@sick.se

**Taiwan**

Phone +886 2 2375-6288  
E-Mail sickgrc@ms6.hinet.net

**Türkiye**

Phone +90 216 587 74 00  
E-Mail info@sick.com.tr

**USA/Canada/México**

Phone +1(952) 941-6780  
1 800-325-7425 – tollfree  
E-Mail info@sickusa.com

More representatives and agencies  
in all major industrial nations at  
[www.sick.com](http://www.sick.com)