



Safety Laser Scanner S300

Compact. Flexible. Intelligent.

Stocked, Distributed, and Supported by

SENSORS
INCORPORATED

507 Kelsey Street • Delano, MN 55328
Phone 763-972-1040 Fax 763-972-1041
Toll Free 888-920-0939
Sensorsincorporated.com

SICK
Sensor Intelligence.

A new class of SICK product: High-end safety in a compact format.

Smaller, but better. This motto guides SICK's extension of a series of safety laser scanners which have been successful worldwide. The S300 series offers outstanding safety features in an incredibly small format and now permits SICK performance even for very cost-sensitive fields of application. No laser scanner offers so much power and user-friendliness and requires so little space. This is a safety concept which will not only convince your colleagues, but also controlling. With SICK you can bring all your machines, plants and vehicles up-to-date.



small

SURPRISINGLY SMALL

The S300 is the smallest safety laser scanner in the world. SICK has packed a surprising number of features into only 102 x 152 x 105 mm (W x H x D). Expect no less than the complete range of functions of a "full size" scanner system such as freely configurable protective field shapes with adjustable object resolutions complemented by a "contour as reference" function. Neither must you do without the technological advances of the SICK system world. The S300 can be integrated into nearly all automation environments. Its standardized SICK Configuration & Diagnostic Software (CDS) makes it a perfect module for a new safety system architecture in your company.



light powerful superior

Photo: Indumat, Reutlingen

SURPRISINGLY LIGHT

Its compact format and light weight (1.2 kg) greatly simplify installation of the S300. Moreover, the system plug is integrated into the housing, can be completely removed and is equipped with screw-type terminals which allows the S300 to be connected to the system either via the rear or lower panels. The data memory integrated into the system plug backs up the configuration of the S300 as a configuration backup (Plug & Play). The data interface for programming and diagnosing the scanner is easily accessible at the front of the device even after installation. The same applies to the integrated status and 7-segment displays.

CONVINCINGLY POWERFUL

8 m warning field and 2 m protective field – of course, freely programmable – for mobile, stationary, horizontal or vertical protection. The compact S300 laser scanner offers an enormous performance range. The device has been approved as a hazardous area, hazardous point, and access protection system, and provides effective protection for your personnel while also reducing operating costs. The S300 ensures fast, long-term and low-cost protection of personnel for first-time installations or for retrofitting machines, plants or vehicles.

SUPERIOR 270°

SICK has faced the challenge: Proven laser scanner technology in a compact format and safety on the highest level. An extremely compact type of construction has been achieved for a short protective field range while significantly increasing the scanning angle. The 270° scanning range of the S300 permits a number of new applications. For example, if two scanners are mounted at opposite corners of an automated guided vehicle, all-round protection can be implemented without additional patching strips. The S300 does not only convince with its unique features, but also with its safety philosophy. IEC/EN 61496-3, Type 3 as well as IEC/EN 61508 and SIL2 approvals make the S300 perfectly suited for use in industrial environments.

S300 from SICK: Switching to power.

One of the formulas of success of SICK laser systems is their enormous range of applications. Straight through all sectors.

You want to cut down barriers and improve storage space utilisation?

You require protective fields which can be adjusted quickly for more machine efficiency?

You want more transport capacity for your mobile service robots?

Or you want to increase the general level of personnel safety in your company?

Forget space-eating mechanical vehicle and plant protection systems which are subject to wear and tear. With the S300 you can easily modernize the safety solutions for your company in an economical way.

The S300 can be adapted optimally to changing conditions. No matter what kind of protection system you are planning: The S300 offers you a new kind of flexibility.

This does not only apply to the use of automated vehicles, but also to stationary applications. The S300 is suitable for both horizontal hazardous area protection as well as vertical hazardous point or access protection.

Neither must you do without proven features such as integrated inputs for external device monitoring (EDM) and reset/restart. In addition, the Intelliface family also permits access to many safety bus systems via the integrated and safe device communication interface (EFI).

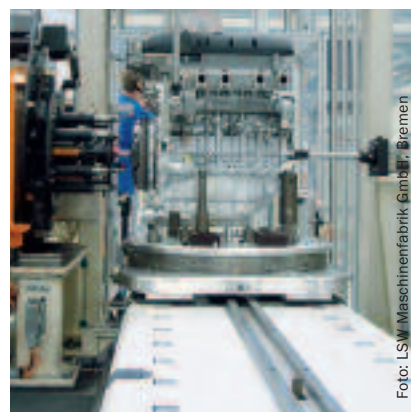



Optimized machine and plant safety with a single scanner – the phenomenal 270° scanning angle of the S300 makes it possible. At low cost.

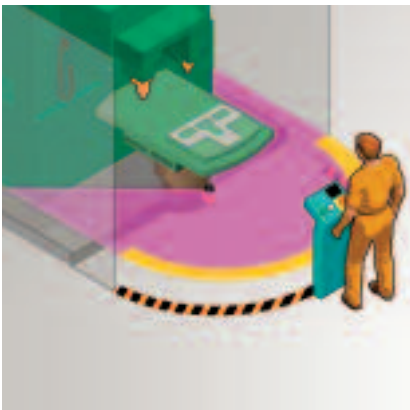

Small dimensions, flexibly switchable warning and protective fields. The S300 facilitates dense overhead conveyor traffic while ensuring reliable personnel and plant protection.

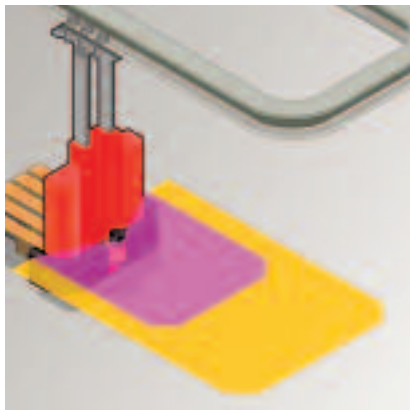

Perfect vertical access control with „contour as reference“ function. For protecting an access (distinguishes between humans and goods). Advantage: The protective function of the scanner is maintained at all times (no muting).

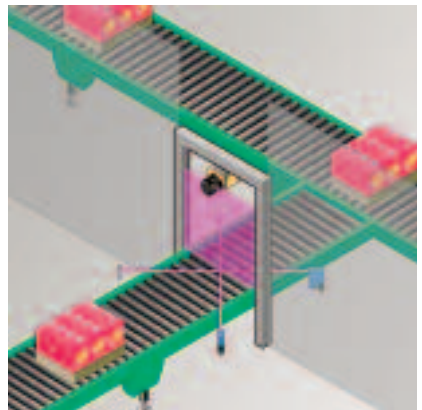

Automated guided systems in highly automated environments – the S300 is a reliable personnel protection system for the direction of movement.

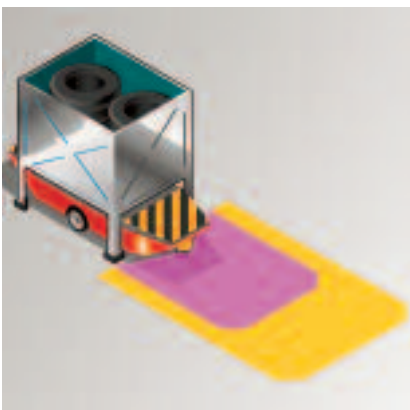

Two scanners of the compact S300 series suffice to ensure reliable all-round protection - the unbeatable solution for small transport vehicles.

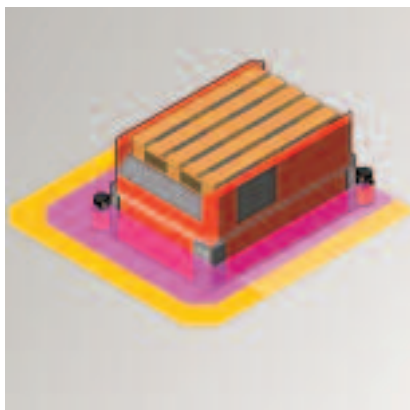

S300 system variants: Highly accurate safety systems.

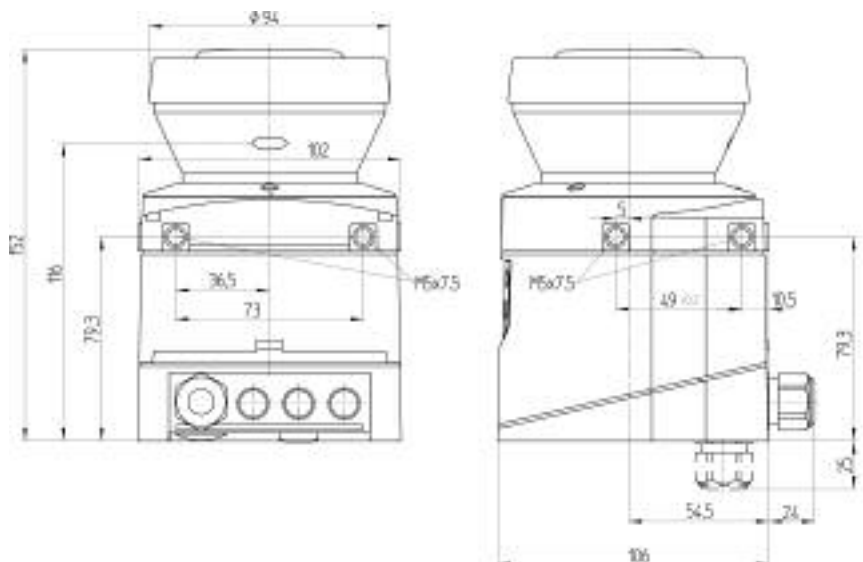

Photo: Paul Hartmann AG, Heidenheim

The flexibility and variant diversity of the S300 are the basis for many intelligent, simple-to-install and easy-to-control safety solutions. The model variants of the S300 system literally leave no „safety gap“ for stationary or mobile applications.

The housing

- Extremely compact type of construction
- Weighs only 1.2 kg
- Device connections either on rear or bottom panels
- Integrated configuration memory
- User-friendly status indicators
- Easily accessible data interface for programming/diagnosis
- Different mounting kits are available



Compact laser scanners from SICK: Different variants for seamless protection.



	S300 STANDARD	S300 ADVANCED
Application		
Hazardous area protection (horizontally)	•	•
Access protection (vertically)	•	•
Hazardous point protection (vertically)	•	•
Protective field range (in m)	2.0	2.0
Warning field range (in m)	8.0	8.0
Number of protective/warning fields	1	2
Scanning angle (in °)	270	270
Response time (in ms)	80	80
Resolution (in mm)	30, 40, 50, 70	30, 40, 50, 70
Static inputs for protective field switching	-	•
Incremental encoder connections for speed-dependent protective field switching	-	-
Integrated external device monitoring (EDM)	•	•
Data interface		
RS-232	•	•
RS-422	-	-
EFI interface for the bus interface and for linking two S300	-	•
Plug and Play on device replacement (integrated configuration memory in the system plug)	•	•
7-segment display for easy on-site diagnostics	•	•
Supply voltage, DC (in V)	16.8... 30.0	16.8... 30.0
Power consumption (in W, without ext. load)	8	8
Weight (in kg)	1.2	1.2
Dimensions (W x H x D) in mm	102 x 152 x 105	102 x 152 x 105
Category according to EN 954-1	Type 3, IEC/EN 61496-3, IEC 61508 SIL2	Type 3, IEC/EN 61496-3, IEC 61508 SIL2



S 300 PROFESSIONAL	S 200
•	•
•	•
•	•
2.0	1.5
8.0	8.0
4	1
270	270
80	80
30, 40, 50, 70	30, 40, 50, 70
•	-
•	
•	•
•	•
•	-
•	-
•	-
•	•
16.8 ... 30.0	16.8 ... 30.0
8	8
1.2	1.2
102 x 152 x 105	102 x 152 x 105
Type 3, IEC/EN 61496-3, IEC 61508 SIL2	Type 2, IEC/EN 61496-1

**Safety laser scanner
S200**

- Now also for Cat 2 applications
- For horizontal and vertical use
- Adjustable object resolution
- Flexible, easily integratable
- Low-cost Cat 2 solution with state-of-the-art technology



**Safety laser scanner
S3000**

The S3000 product series with expanded features is available for more complex applications (compatible with S300 laser scanners).



Foto: MLR System GmbH

S300 STANDARD

The low-cost solution for applications which require only a single protective/warning field.

S300 ADVANCED

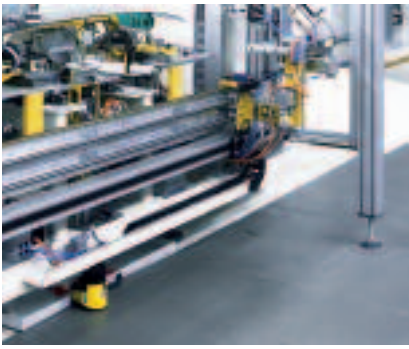
With two switchable protective/warning fields – the system of choice for applications with changing processing positions, e.g. insertion stations, robots, moving work benches.

S300 PROFESSIONAL

Optimal protection, e.g. for small, freely roaming transport systems and service robots whose protective fields must be flexibly adapted to changing speeds; with four protective fields and four warning fields, incremental encoder inputs and RS-422 data interface.

- Basic data**
- 1 protective and warning field
 - 270° scanning angle
 - Configuration memory in the system plug
 - Adjustable object resolution
 - Input for external device monitoring (EDM)
 - Input for stand-by mode

- Basic data**
same as S300 Standard, additionally with
- 2 switchable protective/warning fields
 - EFI – safe SICK device communication

- Basic data**
same as S300 Standard, additionally with
- 4 switchable protective/warning fields
 - Facility for connecting incremental encoder
 - RS-422 data interface
 - EFI – safe SICK device communication

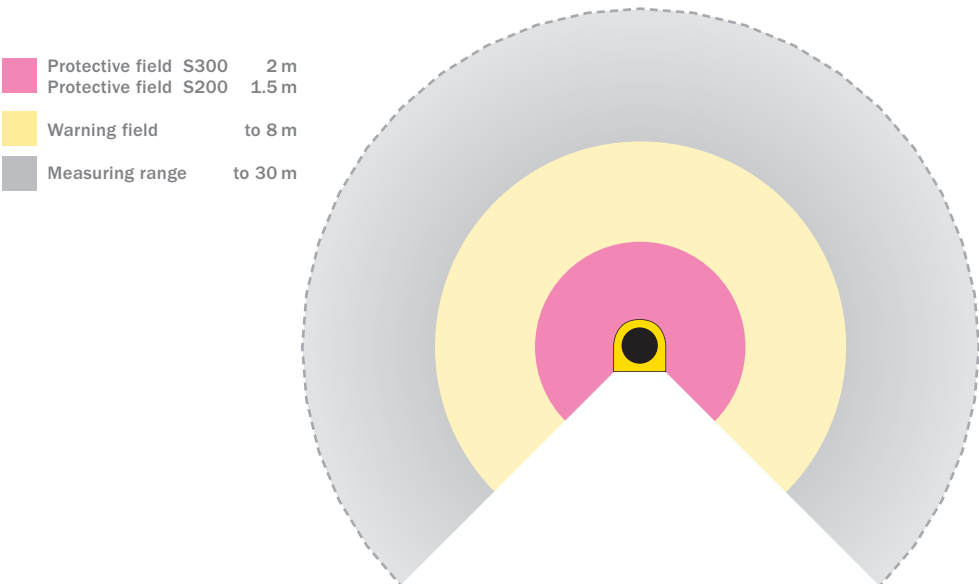

RANGE OF EXPERTISE

INDUSTRIAL SENSORS

Our complete range of sensors provides answers to suit any application in the field of automation. Even under rugged ambient conditions objects are reliably detected, counted and positioned in respect of their form, location and surface finish, as well as their distances established with pin-point accuracy.



INDUSTRIAL SAFETY SYSTEMS

Comprehensive safeguarding of both personnel and machinery! As specialists in Sensor Technology, SICK develops and manufactures pioneering products for providing protection in hazardous zones, dangerous locations and for safeguarding access points. By providing services, which encompass all aspects of machine safety and security, SICK is setting new standards in Safety Technology.



AUTO IDENT

Whether the tasks involve identification, handling, classification or volume measurement, innovative Auto Ident systems and laser measuring systems function extremely reliably, even under rapid cycle times. They conform to the latest Standards and can be simply and speedily integrated in all industrial environments and external applications.



ANALYZERS AND PROCESS INSTRUMENTATION

System control, maintaining setpoints, optimising process control and monitoring the flow of materials – the instruments and services for Analysis and Process Measurement, supplied by SICK MAIHAK, are setting the standards for these applications in terms of Technology and Quality.



Worldwide present with subsidiaries in the following countries:

Australia
Belgium/Luxembourg
Brasil
Česká Republika
China
Danmark
Deutschland
España
France
Great Britain
India
Italia
Japan
Nederlands
Norge
Österreich
Polska
Russia
Schweiz

Singapore
Republic of Korea
Republika Slovenija
Suomi
Sverige
Taiwan
Türkiye
USA/Canada/México

Please find the detailed addresses and more representatives and agencies in all major industrial nations at www.sick.com