

Stocked, Distributed, and Supported by

SENSORS
INCORPORATED

507 Kelsey Street • Delano, MN 55328
Phone 763-972-1040 Fax 763-972-1041
Toll Free 888-920-0939
Sensorsincorporated.com

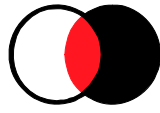

SENSOPART

Mounting and operating instructions SmartRange

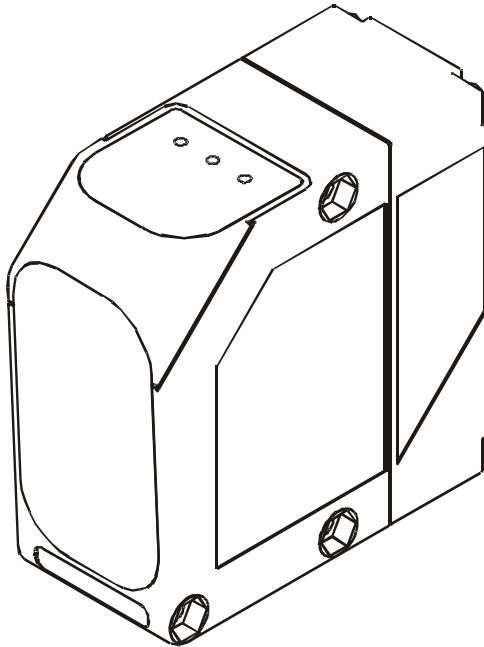

FT 90 ILA

Distance measuring device

FT 91 ILA

Distance sensor

FR 90 ILA

Reflector distance measuring device

FR 91 ILA

Reflector distance sensor

Copyright (English)

No part of this document may be reproduced, published or stored in information retrieval systems or data bases in any manner whatsoever, nor may illustrations, drawings and the layout be copied without prior written permission from SensoPart Industriesensorik GmbH.

We accept no responsibility for printing errors and mistakes which occurred in drafting this manual. Subject to delivery and technical alterations.

Signs and Symbols

Warning



This symbol signals passages in the manual which must be observed at all times. Non-compliance can cause injuries or material damage.

Warning Laser



This symbol appears in front of warning passages concerning the danger of laser beams.

Information



This symbol signals passages with useful information.

Safety information



It is essential that this manual is read, thoroughly understood and observed before setting the Fx9xILA sensor into operation.

The Fx9xILA sensor may only be connected, mounted and adjusted by qualified personnel. Interventions and alterations to the device are not permissible!

The Fx9xILA sensor is not a safety component as described by EU machine directives.

In set-up mode, the Fx9xILA complies with laser protection class 2 according to DIN EN 60825-1: status 2008-05.



The technical requirements comply with EN 60947-5-2, 2000 edition.

In running mode, the Fx9xILA works with a laser of protection class 1



Never look into the path of the laser. Do not suppress the reflex to close the eyelids. Gazing into the beam path for longer periods can damage the retina of the eye.

When mounting the sensor, ensure if possible that the beam path is sealed off at the end.

The laser must not be directed at people (head height).

When aligning Fx9xILA, ensure that there are no reflections on reflective surfaces.

Should the safety label on the Fx9xILA sensor be partly covered due to its installation position, other safety labels are to be positioned on visible parts of the sensor. When applying the new safety label, make sure that you cannot look into the laser beam whilst reading it.

I. Description of device

FR90ILA / FR91ILA (measurement of distance to reflector)

The **SmartRange** sensors **FR90ILA** and **FR91ILA** are optical distance measuring devices which detect the distance to a reflector down to the millimetre in seconds. The measured values are made available via integrated digital standard interfaces.

The sensors operate according to the principle of pulsed time of flight measurement.

They are particularly suitable for use in applications involving the positioning of cranes, high bay stackers as well as in high-rise and small-parts warehouses. The **FR90ILA** and **FR91ILA** devices differ in performance data (see the chapter on technical data).

FT90ILA / FT91ILA (measurement of distance to object)

The **SmartRange** sensors **FT90ILA** and **FT91ILA** are optical distance measuring devices which measure the distance down to the millimetre in seconds. The measured values are made available via integrated digital standard interfaces.

The sensors operate according to the principle of pulsed time of flight measurement.

They are particularly suitable for use in many applications in automation technology where parts must be detected or measured over long distances. The **FT90ILA** and **FT91ILA** devices differ in performance data (see the chapter on technical data).

SmartRange sensors are equipped with the following:

- ◆ LCD display and 3 buttons for complete on-site set-up
- ◆ RS422 interface
- ◆ SSI compatible interface (GRAY or BIN, 24 or 25 bit)
- ◆ 2 signal outputs and an error and plausibility output
- ◆ Bus communication with external bus adapter
- ◆ One 4 to 20 mA analogue output (only with FT90ILA und FT91ILA)

Appropriate use

SmartRange sensors are optical measuring systems for the measurement of distances and must only be used for this purpose.

NEVER use these sensors in applications where human safety is at risk.



Laser safety information

The sensor is equipped with a red light pilot laser, laser safety class 2, for alignment purposes.

The measuring laser is an infrared laser belonging to laser safety class 1.



Running mode: Laser safety class 1

Set-up mode: Laser safety class 2

Never look into the beam !

Wave length λ :	650 nm
Maximum power P_{max} :	3 mW
Impulse duration t_p :	0.3 μ s, T: 1 μ s
DIN EN 60825-1: 2008-05	

Contents of delivery

The following is supplied in the standard delivery:

- ◆ **SmartRange** sensor **Fx9xILA**
- ◆ Operating manual

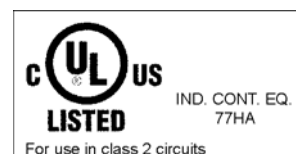

II. Commissioning / operating

Connection

Once the device has been connected to the power supply, the display shows the measured value currently detected should an object / reflector be in the path of the beam. The green "POWER" LED lights up.

Aligning FR9xILA (measurement of distance to reflector)

It is possible to align the device over a max. distance of approx. 50 m using the integrated red light pilot laser (see chapter operating).

For larger distances, the aligning aid listed in the accessories is to be used. This aligning aid, makes it easily possible to check the position of the red light pilot laser spot on the reflector at very long ranges (≥ 100 m). When aligning, first check that the light spot is in the centre of the reflector at a very short distance (e. g. ≤ 1 m). The reflector is then moved to its final position with the longest range and the position of the light spot is checked again and adjusted if necessary. Finally, check the position of the light spot again close-up. The light spot must always be in the centre of the reflector whatever the position.

The fine adjustment set, available as an accessory with part no. 599-91003, can be used for finer adjustment.

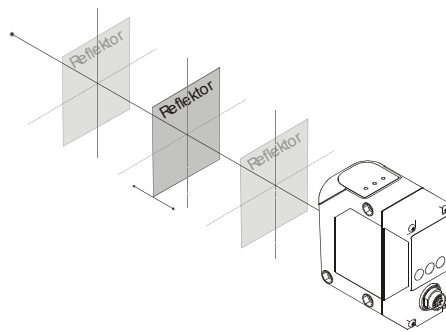

Different reflector types are available according to the distance range required. Only use the reflectors specified below.

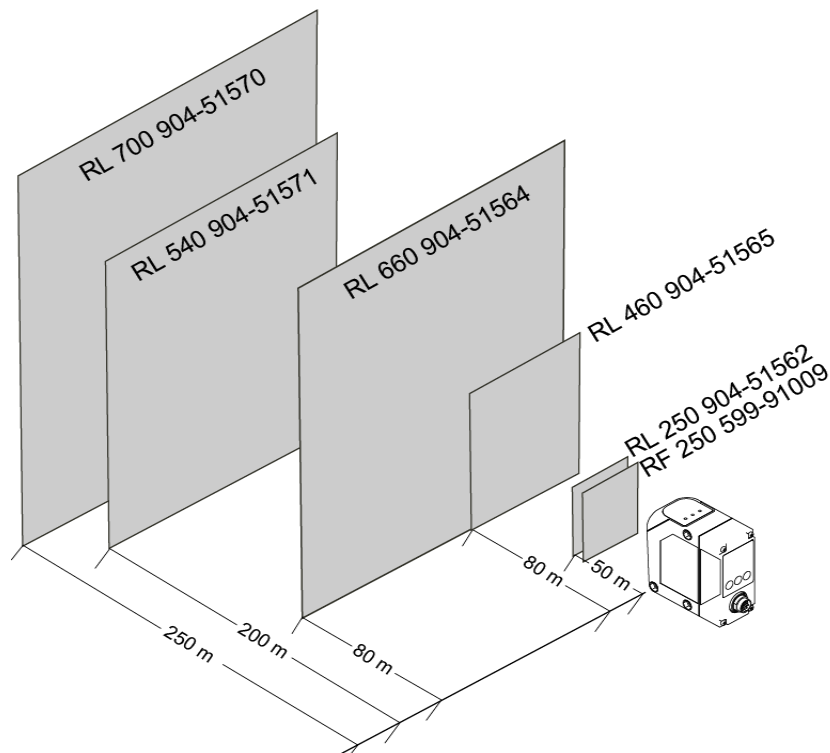

Aligning FT9xILA (Measurement of distance to object)

Alignment can be carried out with the aid of the integrated visible pilot laser (see chapter “Operation”). The fine adjustment set, available as an accessory with part no. 599-91003, can be used for finer adjustment. Observe the information pictured below when aligning the devices.

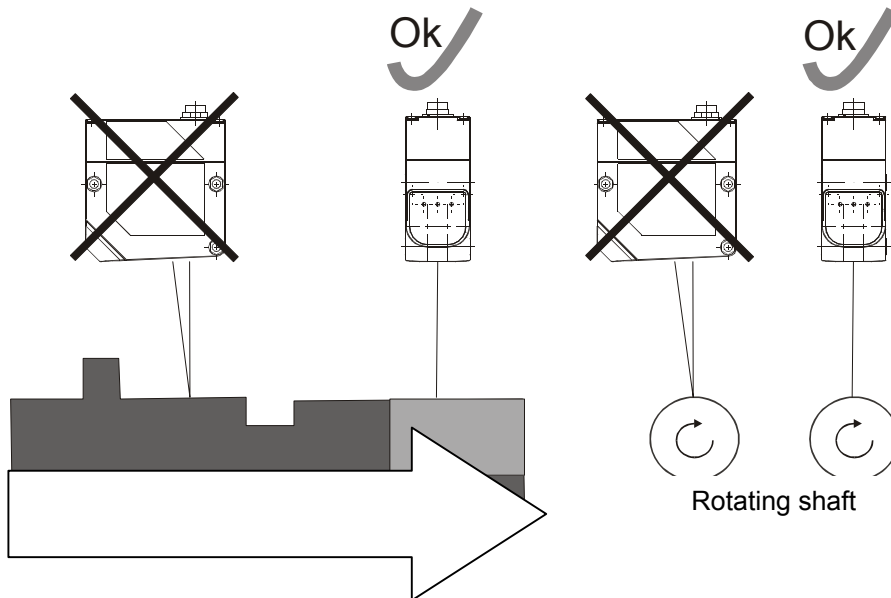

Dimensions of light spot Fx9xILA

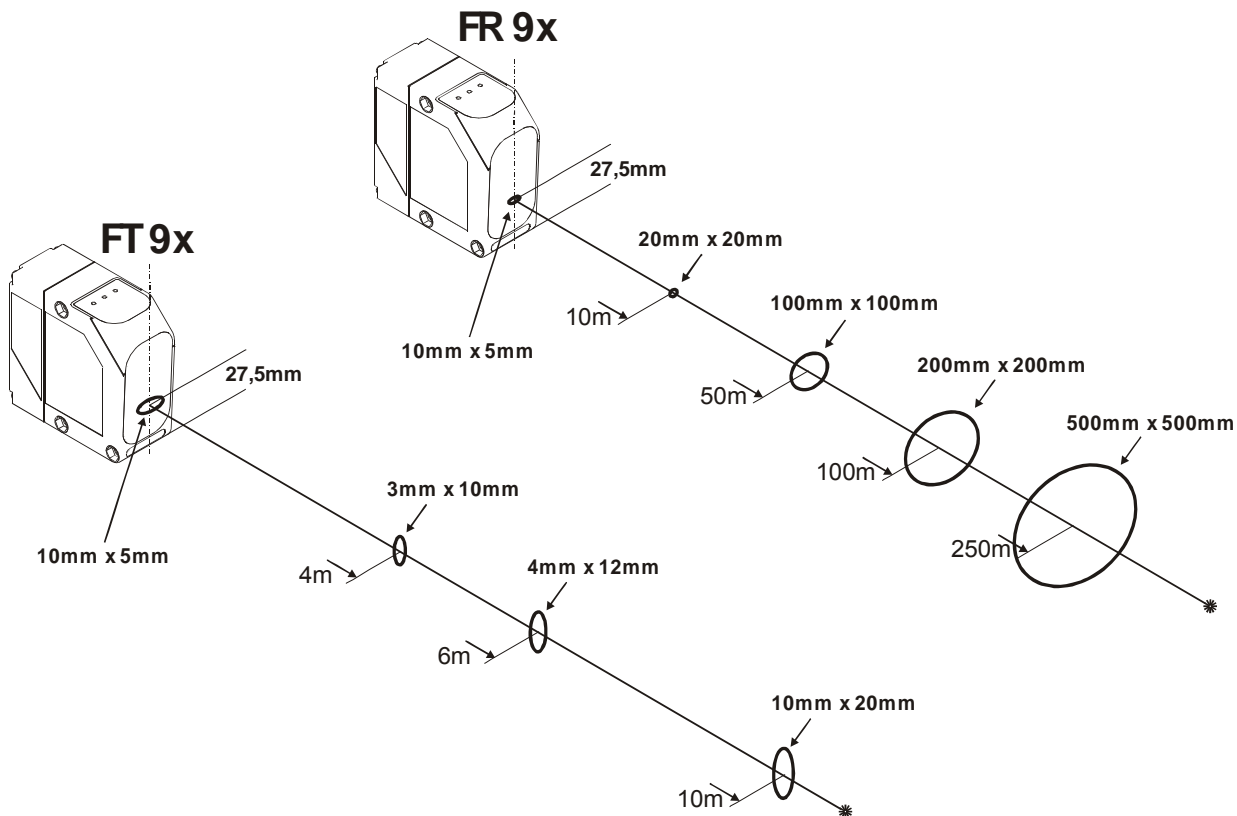

III. Operation

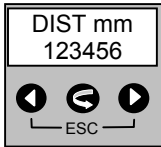

The **Fx9x SmartRange** sensors are equipped with an LCD display and 3 operating buttons which control all instrument functions. All parameters can be adjusted and measured values can be read via the integrated serial interface using PC software or your own special application programme. (Parameters of RS422 interface can only be altered on the device)

In measuring mode:



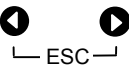

the text “DIST mm“ or “DIST INCH“ (depending on unit selected) and the actual measured value are displayed on the screen.

The three operating buttons have the following general functions

Button	Name	General operating functions
	Enter button	General: Selects function and switches one menu level down – or records value and switches one menu level up In operating mode: Switches to menu level (If password function is active, switches to password entry. Measuring mode remains active until correct password has been entered). When editing e.g. switching points: switches cursor position from right to left or ends entry when cursor is at the far left.
	Right arrow button	General: scrolls to the next function (right), or increases current digit by 1 when editing. In “QuickSet“ menu, it enables the teach-in of Q2 In measuring mode, press this button to make the display light up.
	Left arrow button	General: scrolls to the next function (left), or reduces current digit by 1 when editing In “QuickSet“ menu, it enables the teach-in of Q1 In measuring mode, press this button to make the display light up.
	ESCape function Left and right arrow buttons simultaneously	Cancels active function and switches to next menu level above (important: buttons must be pressed <u>simultaneously</u> , previous value is maintained unaltered)

Selecting menu items:

Menu items are displayed in two forms:

1. < Menu item > , with this display, it is possible to switch to another menu item with  , or select the menu point with 
2. → Menu item , with this display, the  keys can be used to alter the value.

Note:

The red pilot laser and the display’s background lighting are always active in set-up mode.

When the sensor is switched on, the following message appears for approx. 2 sec.:
The software revision number must always be quoted when contacting the manufacturer with technical queries.

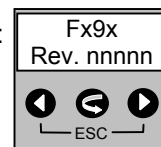

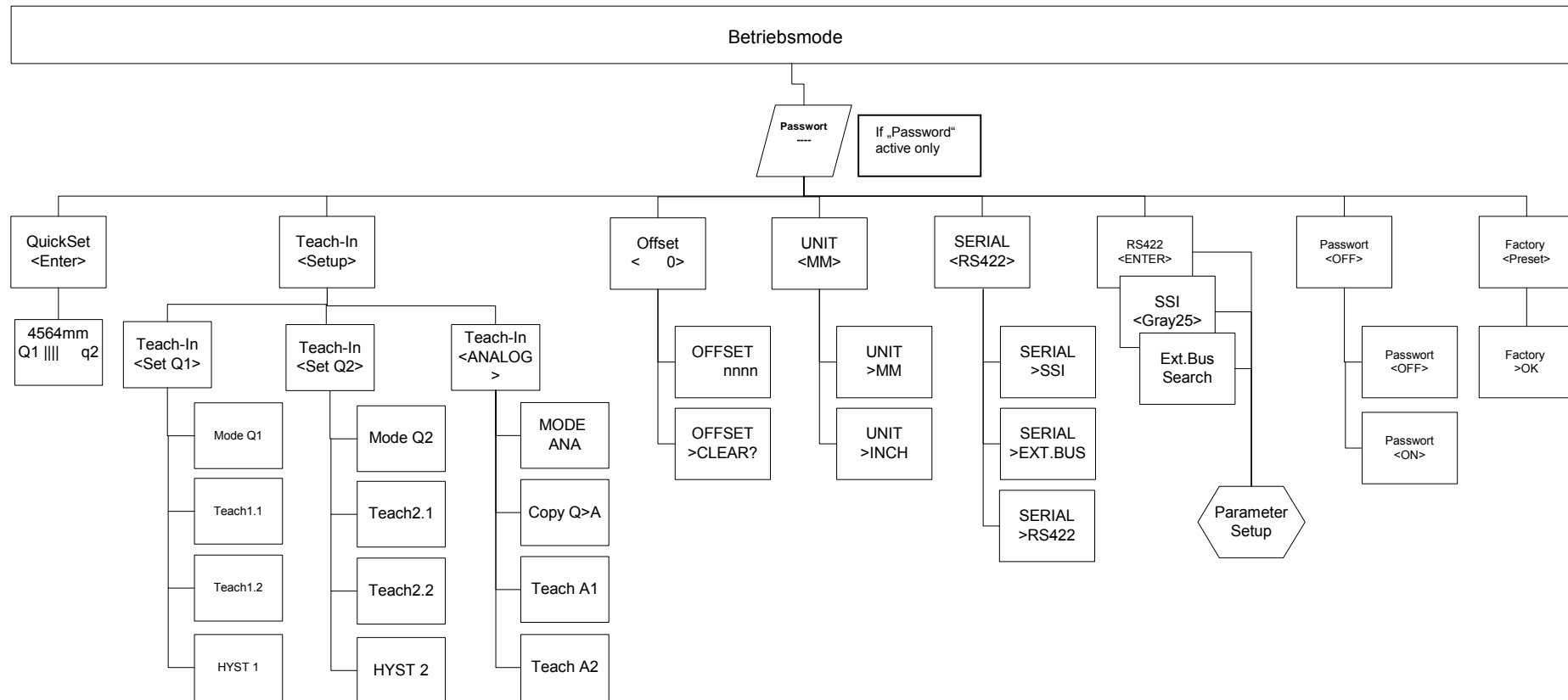

Menu structure





Operating mode (DIST mm)

When in operating mode, “DIST mm” or “DIST INCH” appears in the first line, depending on the active unit, and the current measured value is displayed in the second line.

When the   buttons are pressed, the screen lights up.

QuickSet

The current measured value is displayed in the top line. In the centre of the bottom line, the energy value is displayed as an alignment aid in the form of a bar graph.

Q1 and Q2 can be “taught” directly by pressing the appropriate button  
(Teach function not if SSI mode is active.)

Depending on the selected mode of signal outputs (see Teach-in menu), the rising or falling edge of the signal output is taught with the set hysteresis in “Single switching” mode. In “Double switching” mode, the teach point marks the centre of the switching points positioned 100 mm symmetrically either side (= rising or falling edge) with the set hysteresis.

These display symbols have the following meaning: **Q1** = output 1 **ON**; **q1** = output 1 **OFF**
Q2 = output 2 **ON**; **q2** = output 2 **OFF**

(also indicated by yellow LEDs on the front of the device)

Quit the menu with the Enter button or ESCape function.

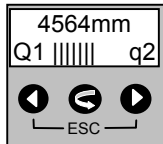

Example: QuickSet menu; current measured value 4564mm, Q1 ON, Q2 off, receiving energy approx. 50%

Unit (mm)

Unit makes it possible to choose between millimetres and inches as the display and output unit. The inch display and output via the interface is in 1/10 MIL or *100 Inch (1 MIL = 1/1000 inch) , i.e. display value: “123456” (/100 Inch) corresponds with 1234.56 inch or 1234560 MIL.

Serial Select (RS422 / SSI / EXT_BUS)

With **Serial Select** it is possible to select the interface from RS422, SSI1/10, SSI1/8 -compatible or EXTERNAL BUSadapter. When EXT BUS is selected, “SEARCH BUS ...” appears in the display until the connection is established. (Bus adapters are available as accessories). Once the connection has been successfully established, the above-mentioned text disappears. If the connection cannot be established, the text remains in the display and the process must be cancelled with the ESCape buttons and the process can be restarted once electrical connection has been restored.

RS422 or SSI-compatible or BUS-ADDR (RS422 / SSI / EXT_BUS)

Depending on the setting made in **Serial Select**, the appropriate interface parameters are displayed or altered. The following settings are possible: (delivery status = underlined)

- RS422
 Baud rate: 4.8 or 9.6 or 19.2 or 38.4 or 57.6 kBaud
 Data bit: 8 or 7
 Stop bit: 1 or 2
 REPEAT or SINGLE: REPEAT means that the sensor continuously sends measured data via the serial interface without waiting for a request. In SINGLE mode, a string of measured data is only supplied on request
- SSI:
 Different codes: 1/10 = LSB = 0.1mm (10MIL) or 1/8 = LSB = 0.125mm (8MIL)
BINARY24 or BINARY25 or GRAY24 or GRAY25 are possible
- BUS-ADDR:
 Address for external bus adapter: Here it is possible to adjust the address for the external bus adapter, e.g. Profibus. The address range stretches from 3 to 124. The addresses 0-2 are as a rule reserved for the Profibus master and are therefore disabled.



The factory setting must be selected for connection with ProgSensor! (original PC Software)

OFFSET (0)

An offset value can be entered or taught in the value range +/-100,000mm (or corresponding inch value). The measured value is then increased or reduced by the programmed offset value, depending on the preceding sign. This can compensate a mounting position which does not correspond with the zero point of the device. If an offset value is taught, it is automatically given a negative sign when adopted, i.e. the teach-in position corresponds with the zero point. Delivery status = 0mm. (The preceding sign can also be set manually). The offset value can be set back to "0" with the "CLEAR" function.

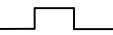
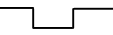

Example: Actual distance: 3000mm
 Offset value: - 1200mm
 Output value: **1800mm**

TEACH IN (Delivery status = Limit value of measurement range)

	Qx single switching
	<u>Qx single switching</u>
	Qx double switching
	<u>Qx double switching</u>

Teach-in or manual input of switching points is possible

Hysteresis: Range Fx90=5 or Fx91=10 to 254mm, adjustable in +/-1 mm steps, symmetrically around the switching point (if upper limit is reached, limit value of measurement range is valid as upper limit)





Analog output 4 to 20 mA (only FT9x detector)	
	<u>Mode 1, rising characteristic curve</u>
	Mode 2, falling characteristic curve



COPY Q => A:
Q1 & Q2: Switching point Q1.1 becomes 0% point (A1); Q2.1 becomes 100% (A2) of the characteristic analog curve.
Q2 & Q1: Switching point Q1.1 becomes 100% (A2) point; Q2.1 becomes 0% (A1) of the characteristic analog curve.
TEACH A1 A2: Teach-in of 0% (A1) and 100% points (A2) or manual input possible.

A minimal distance of 300 mm between points A1 and A2 must be observed.

Editing:

When the teach-in function has been completed with  , the value measured at this moment is adopted and the device switches one menu level up.

If the teach-in function is ended with one of   , the edit mode is activated. The cursor flashes below the digit on the far right-hand side which can be increased or reduced by 1 using the   buttons.

The  button is used to switch to the next digit to the left and each digit can now be altered. Once you have reached the last digit on the left-hand side, press  again to adopt the manually edited value and switch one menu level up.

FACTORY PRESET

All settings are reset to delivery status.

PASSWORD (OFF)

Activate or deactivate password entry. Delivery status = inactive (OFF).

The password is permanently "1234" and cannot be changed.

When the device is set to "Password ON" , it is only possible to quit operating mode when 1234 has been entered as password.

Measuring mode continues in the background whilst the password is being entered. Should no entry be made in the password input menu over a period of approx. 10 seconds, operating mode reappears on the display.

Operating example for menu: QuickSet

Menu level 1 Operation 1.0						
	Display: 1st line: Text "DIST mm" 2nd line: current measured value ⏪ Password input					
Menu level 1 PASSWORD1.1		(Only when "PASSWORD" active, delivery status = inactive)				
	⏩ Increases current digit by 1 ⏪ ⏴ Reduces current digit by 1 ⏴ ⏪ Jumps one digit further or "confirms input" when the far left digit has been reached and is pressed. ⏪ Menu level 2: if input is correct and completed with Operating mode: if input is wrong or with timeout after approx. 10 sec.					
Menu level 2 QuickSet 2.1	UNIT 2.2	SERIAL 2.3	RS422/SSI 2.4	OFFSET 2.5 2.x	Password 2.8
⏪ Level 3						
Menu level 3 QuickSet 2.1.1						
	⏩ ⏴ Teach-in Q1 or Q2 ⏪ Confirm input and switch one menu level up ESC Switch one menu level up EE Energy value for alignment					

IV. Commands via the serial interface (RS422 protocol)

All commands have the following structure: **<STX><Command><[Data]><EOT>**

All commands are answered by Fx9xILA as follows:

<NAK> = the command was not recognised or the data is outside the limit values.

or

<ACK> = the command was recognised and executed, the command requires no return data.

or

<Data> = the command was recognised and the requested data has been sent.

Definitions:

STX = start transmission = 02h = CTRL B

EOT = end of text = 04h = CTRL D

NAK = no acknowledge = 15h = CTRL U

ACK = acknowledge = 06h = CTRL F

Command = 3 digit command (ASCII text)

[Data] = whole numbers (ASCII text)

In ASCII text (command+data) spaces and capitals/small letters are ignored.

User commands and their meaning

Comm and	Name	Data to Fx9x	Data from Fx9x	Meaning
„GAP“	get all parameters	-	all parameters in text format: „Fx9xILA \$Revision X.XX\$“ „pilot is on/off/xx seconds on“ Uart mode „Q1: AA MODE=BB LIMIT1=CC LIMIT2=DD HYST=EE INV=ON/OFF“ „Q2:AA MODE=BB LIMIT1=CC LIMIT2=DD HYST=EE INV=ON/OFF“ (proximity switch only : „Qana: VALUE=FF LIMIT1=CC LIMIT2=DD INV=ON/OFF) „output = GC“ „offset = YYYY“ „password dis/enabled“ „Error-Status = DDDDDDD“	all parameters of Fx9x are read: X.XX: Revision no. YYYY: User offset [mm] or [10 MIL] AA: „ON“=HIGH output, „OFF“=LOW output BB : Mode: „0“ = Output off, „1“ = 1 Switching point „2“ = 2 Switching points CC: Switching point 1, Offset..12000+Offset DD: Switching point 2, Offset..12000+Offset EE: Hysteresis, 0 to 254 [mm] GG: Unit of meas., „10 MIL“ or „MM“ DDD : Error status: FF: Analog value, 0 to 4095 Output of error status, with D=“0“: no error D=“1“:error: D7: Transmitter faulty D6: Receiver blinded or faulty D5: Temperature warning: T < -10°C or T > +70°C D4: Target out of range or transmitter faulty D3: Temperature error: T > +80°C D2: Supply voltage too low D1: PLL unlocked D0: always “0“
„ECM“	execute continuous measurement	-	ACK	continuous measurement output is set and triggered by the next request for measured values
„GDB“	get energy	-	Energy value -0 to -120dB	indicates the amount of receiving energy
„GNR“	get serial number	-	„xxxxxxxxxx“	Serial no. is emitted as ASCII test (max. 24 characters).

„GSI“	get error status	-	„DDDDDD“ 76543210	Output of error status, with D=“0“: no error D=“1“:error: D7: Transmitter faulty D6: Receiver blinded or faulty D5: Temperature warning: T < -10°C or T > +70°C D4: Target out of range or transmitter faulty D3: Temperature error: T > +85°C D2: Supply voltage too low D1: PLL unlocked D0: always “0“
„GTE“	get temperature	-	„±DDD“	DDD = internal temperature in °C
„GVE“	get version	-	„Fx9x \$Revision X.XX\$“	Software version is sent
„GCM“	help command / get commands	-	All available commands	All available commands are sent in text format
„ICM“	input continuous mode	„0“ , „1“	ACK	Measurement mode setting: “0“ = continuous measurement output, “1“ = output of single measurement values
„IDO“	input offset	-12000..+12000 or -48000..+48000	ACK	Setting offset in [mm] or [INCH * 100]
„IH1“	input hysteresis Q1	„000“.. „254“ or „000“..“999“ (INCH)	ACK	Setting hysteresis around switching points of Q1 in [mm] or [INCH * 100]
„IH2“	input hysteresis	„000“.. „254“ or „000“..“999“ (INCH)	ACK	Setting hysteresis around switching points of Q2 in [mm] or [INCH * 100]
„IL1“	input limit Q1 – 1	Offset ... +12000+Offset or Offset .. 48000+Offset	ACK	Setting the first switching point of Q1 in [mm] or [INCH*100]
„IL2“	input limit Q2 – 1	Offset ... +12000+Offset or Offset .. 48000+Offset	ACK	Setting the first switching point of Q2 in [mm] or [INCH*100]
„IL3“	input limit Q analog 1	Offset ... +12000+Offset	ACK	Proximity switch only: Setting 0% point of characteristic analog curve
„IL4“	input limit Q1 – 2	Offset ... +12000+Offset or Offset .. 48000+Offset	ACK	Setting second switching point of Q1 in [mm] or [INCH*100]
„IL5“	input limit Q2 – 2	Offset ... +12000+Offset or Offset .. 48000+Offset	ACK	Setting second switching point of Q2 in [mm] or [INCH*100]
„IL6“	input limit Q analog 2	Offset ... +12000+Offset	ACK	Proximity switch only Setting 100% point of characteristic analog curve
„IM1“	input mode Q1	“0“, “1“, “2“	ACK	“0“ = inactive, “1“= 1 switching point, “2“ = 2 switching points
„IM2“	input mode Q2	“0“, “1“, “2“	ACK	“0“ = inactive, “1“= 1 switching point, “2“ = 2 switching points
„INA“	input norm Q analog	“0“, “1“	ACK	Proximity switch only “0“= Q, “1“=Q inverted
„IN1“	input norm Q1	“0“, “1“	ACK	“0“= Q, „1“=Q inverted
„IN2“	input norm Q2	“0“, “1“	ACK	“0“= Q, „1“=Q inverted
„IVL“	Input visible laser	“0“, “1“	ACK	„0“ = Pilotlaser off „1“ = Pilotlaser on
„ISB“	input stand-by	“0“, “1“	ACK	“0“ = operation, “1“ = stand-by
„ESM“	trigger single measurement / Execute sing. m.	-	<meas. value>	Request for measured value with single measurement output

„EPW“	write parameter page / execute parameter write	-	ACK	Parameters are stored
-------	--	---	-----	-----------------------

Timing SSI compatible interface

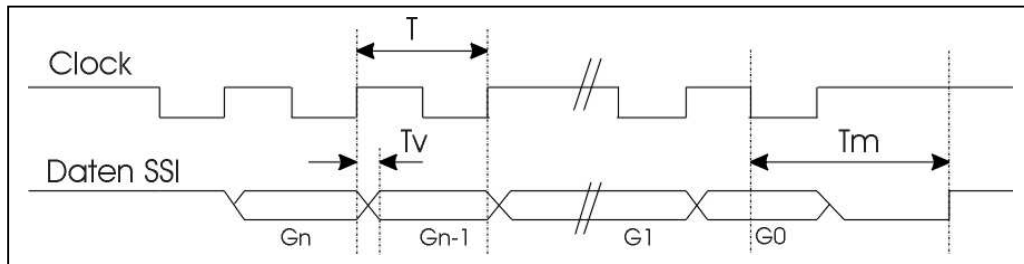

T = Duration of clock signal, minimum 2 μ Sec = 500 kHz, max. 13 μ Sec = 77kHz
 Tv = Delay time max. 360 ns
 Tm = Minimum time between last rising edge and reloading of SSI approx. 24 μ Sec.
 Gn = MSB (here Gray Code)
 24bit transmission: G1 = second LSB, G0 = LSB
 24+E transmission: G1 = LSB. G0 = Error bit
 25bit transmission: G1 second LSB, G0 = LSB

Attention:

With SSI compatible transmission, data is updated in synchronization with the readout cycle. The data is as up-to-date as the time interval between two readouts. An intermittent readout is therefore recommended. After a longer readout interval, the data contents of the first readout can be “out-of-date” and should be ignored.

V. Error messages

In the event of errors, corresponding error messages appear on the display and the error outputs Qs and Qp (active low) are set according to the following table. The error status can be questioned via the “GSI” command. In principle, a combination of several errors can exist. e.g. too low a supply voltage can cause a counter error. In this case the “GSI” command would report “00000110” (via RS422)

Error message on LCD	Output (active low) QS QP		Answer to “GSI” command (get error status)	Meaning
„BLINDING“	active		“01000000“	External light too strong or internal error
„LAS.ERR.“	active	active	“10000000“	Measurement laser faulty
„LOW VOLT“	active	active	“00000100“	Error in supply voltage: voltage too low (or error in measurement of supply voltage)
„NO VALUE“			“00000000“	First measurement after switching-on not yet ready. This message disappears after a short time.
„SEARCH BUS...“			Not possible	Connection to the external bus adapter lost. The sensor automatically tries to restore the connection. This message disappears should connection be restored.
„PLL UNLOCKED“	active	active	“00000010“	Counter error
	active		“00100000“	Temperature warning (below -10°C or above 70°C)
„OVERTEMP“	active (Laser off!)	active (Laser off!)	“00101000“	Temperature too high (above 85°C inside); Measurement switched off!
„Dist (mm) >Maximum“		active	“00010000“	No target in range or sensor badly aligned

VI. Technical data (typ.)

	Distance measuring devices		Reflector device	
	FR90ILA-S2-Q12	FT90ILA-S2-Q12	FR91ILA-S2-Q12	FT91ILA-S2-Q12
	(Reflector device)	(Proximity)	(Reflector device)	(Proximity)
Electrical data				
Supply voltage	18 - 30 VDC			
Residual ripple	10% inside Ub			
Power consumption	< 4.5 W at 25 degrees C			
Q1 / Q2 outputs	100 mA, PNP			
Plausibility output Qp	50 mA, PNP (N.O.)			
Service output Qs	50 mA, PNP (N.O.)			
Protection class	II double-insulated			
Short-circuit protection (all outputs)	yes			
Reverse battery protection	yes			
Serial interface	RS 422 or SSI - compatible (GRAY / BINARY)			
Bus interface	Profibus or DeviceNet via respective gateway (accessory)			
Maximum cable length	100 m			
Analog output	no	4 - 20 mA	no	4 - 20 mA
Optical data				
Measuring ranges				
Reflector (specified)	0.5m to 250m		0.5m to 50m	
black 6%		0.5m to 3m		0.5m to 2m
grey 10%		0.5m to 7m		0.5m to 4m
white 90%		0.5m to 10m		0.5m to 6m
Measuring laser	IR 900 nm, laser protection class 1			
Diameter of light spot	20x20mm @ 10m	3x10mm @ 4m	20x20mm @ 10m	3x10mm @ 4m
Pilot laser	red 650nm, laser protection class 2			
Switching points	adjustable in 1mm steps			
Switching hysteresis	min 10mm (adjustable)		min. 20mm (adjustable)	
Mechanical data				
Dimensions	93mm x 93mm x 42mm			
Weight	approx. 230 g			
Vibration / shock	EN 60947-5-2			
Ambient operating temperature	-10 to + 50 degrees Celsius (-20 to +50 in continuous operation)			
Storage temperature	-30 to + 75 degrees Celsius			
Protection	IP 67			
Connection	12 pin connector, M16			
Housing material	ABS shock-resistant			
Measured values				
Resolution (output of meas. values)	0.1mm or 0.125mm	0.1mm or 0.125mm	0.1mm or 0.125mm	0.1mm or 0.125mm
Repeatability	+/- 2 mm	+/- 4 mm	+/- 4 mm	+/- 5 mm
Linearity	+/- 3 mm 1)	+/- 8 mm	+/- 5 mm 1)	+/- 10 mm
Response time	12 ms	12 ms	12 ms	12 ms
Temperature drift			< 0.5 mm/K	< 0.5 mm/K
Thermal response	< +/- 5mm absolute	< +/- 5mm absolute		
Speed of measurement output	SSI: 1.4ms (SSI cycle 80µs; RS 422 2.9ms at 57.6 kBaud)			
All indications regarding accuracy and distance are based on the specified surface at constant ambient conditions and with a minimum operating time of 15 minutes.				

1) from 2 m

Connector pin assignment

Pin assignment:
Female connector

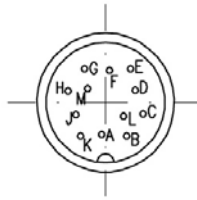

Pin	Name	Cable type 1(12 pin) Colour	Cable type 2 (5 pin.) Colour	Description
A	TX+	White		RS422: Transmitter data / SSI: Data +
B	Q1	Brown	Black	Signal output Q1
C	RX+	Green		RS422: Receiver data / SSI: Clock +
D	analog	Yellow		Analog output 4 to 20 mA (FT9x only)
E	Qs	Grey	Orange	Service output Qs
F	Qp	Pink		Plausibility output Qp
G	U _B	Red	Brown	U _B + 18 to 30 V
H	RX-	Black		RS422: Receiver data / SSI: Clock -
J	NC	Purple		
K	TX-	Grey/Pink		RS422: Transmitter data / SSI: Data -
L	Q2	Red/Blue	White	Signal output Q2
M	GND	Blue	Blue	0 V (GND)

Cable lengths, shield

Cable length RS422

The RS422 interface is defined as a reliable, serial interface in full duplex mode, with transfer rates up to 10 MBaud and a cable length of 1000m

Cable length SSI

The maximum baud rate for reliable data transfer depends on the cable length

Cable length/m	< 25	< 50	< 100	< 200	< 400
Baud rate	< 500 kHz	< 400 kHz	< 300 kHz	< 200 kHz	< 100 kHz

RS422 and SSI screen

The screened connection cable (see accessories) is connected to the sensor connector and the ground terminal of the control cabinet.

VII. Order data / Devices and accessories

Sensors

	Order no.
FT90 ILA-S2-Q12 (Distance measuring device)	591-91000
FR90 ILA-S2-Q12 (Reflector distance measuring device)	591-91001
FT91 ILA-S2-Q12 (Distance sensor)	591-91003
FR91 ILA-S2-Q12 (Reflector distance sensor)	591-91002

Cables 12 wires

Connection cable 12 wires, 10m, 12 pin connector, M16, straight	902-51658
Connection cable 12 wires, 20m, 12 pin connector, M16, straight	902-51663
Connection cable 12 wires, 30m, 12 pin connector, M16, straight	902-51664
Connection cable 12 wires, 3m, 12 pin connector, M16, 90° angle	902-51659
Connection cable 12 wires, 5m, 12 pin connector, M16, 90° angle	902-51660
Connection cable 12 wires, 10m, 12 pin connector, M16, 90° angle	902-51661
Connection cable 12 wires, 20m, 12 pin connector, M16, 90° angle	902-51665
Connection cable 12 wires, 30m, 12 pin connector, M16, 90° angle	902-51666

Connectors

Connector plug straight, 12 pin, M16	022-50832
Connector plug 90° angle, 12 pin, M16	022-50831

Various

Mounting bracket Fx91	599-91002
Fine adjustment for mounting bracket Fx91(set of 2 pcs.)	599-91003
Aligning aid	599-91004
Plug adapter ProfiBus	599-91005
Plug adapter DeviceNet	599-91008
PC software	599-91000

Reflectors

Reflector foil RF250	599-91009
Reflector RL 250	904-51562
Reflector RL 460	904-51565
Reflector RL 660	904-51564
Reflector RL 540	904-51571
Reflector RL 700	904-51570

VII. Dimension illustrations

Fx9x ILA

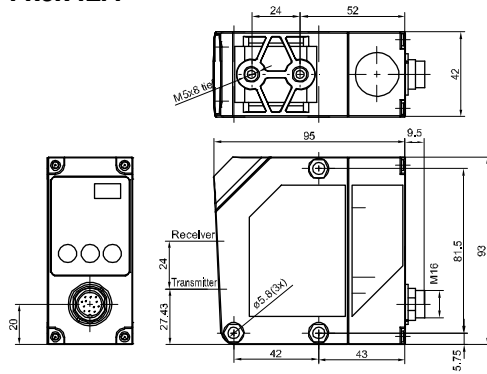

153-00457

Mounting bracket (accessory)

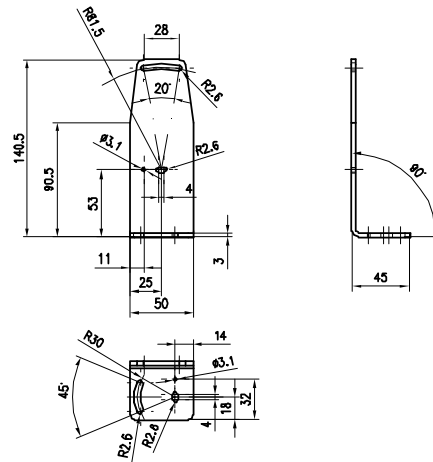

041-13178

Fine adjustment for mounting bracket

The fine adjustment set allows a fine tuning of the Fx9x on the mounting bracket.
X and Y axis can be adjusted by +/- 3Grad degrees.
Mounting see picture on the right.

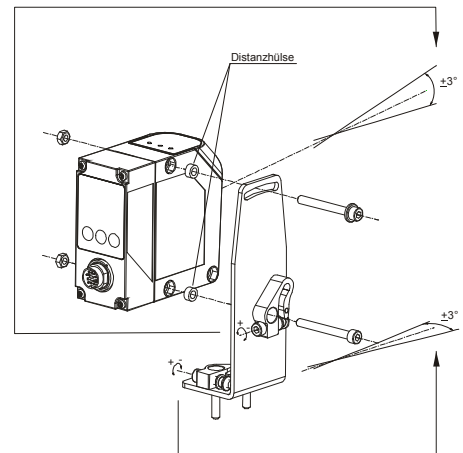

155-00212

Aligning aid

The aligning aid allows to see the spot of the pilot laser at large distances.

Using the aligning aid:

- Mount the aligning aid on Fx9x front side.
- Activate any menu item (->Pilotlaser on)
- Look into the scope window and focus the spot.

The real light spot is exactly in the same position as the visible spot displayed in the aligning aid.

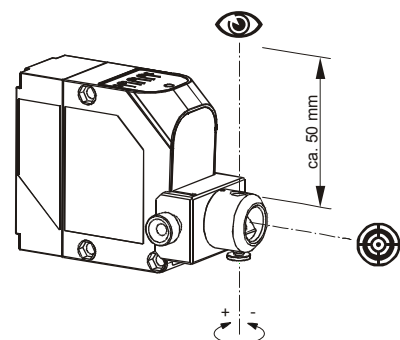

155-00213

Reflectors

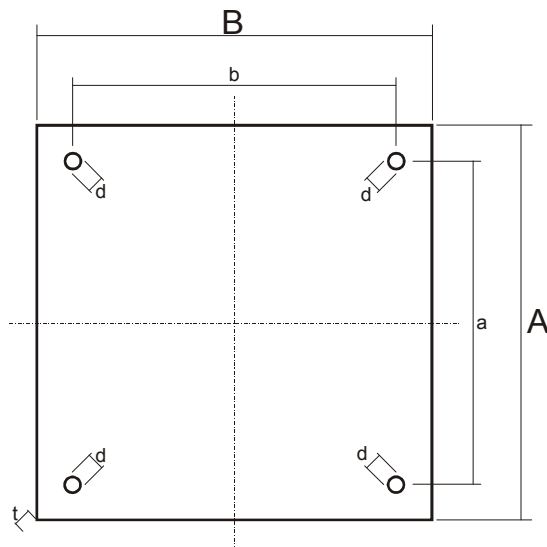

	A(mm)	B(mm)	a(mm)	b(mm)	d(mm)	t(mm)
RF 250	250	250	---	---	---	0,5
RL 250	248	248	218	218	6,5	4,5
RL 460	460	460	430	430	6,5	4,5
RL 660	660	660	630	630	6,5	4,5
RL 540	540	540	510	510	6,5	6,8
RL 700	700	700	670	670	6,5	6,8

Appendix

ProfiBus, DeviceNet connector adapter

Measured value:

Binary output: none

Binary input: none

Analog output: none

Analog input: 2 * 16bit -> (measured value in millimetres (word 0: measured value bit 0 to 15, word 1: measured value bit 16 to 32))

Error status:

Error output consisting of 16 bits

Error bits:

Bit 15 to Bit 8: always "0"

Bit 7: No start, transmitter faulty

Bit 6: Receiver blinded or faulty

Bit 5: Temperature warning: $T < -10^{\circ}\text{C}$ or $T > +70^{\circ}\text{C}$

Bit 4: No stop signal, target out of range or receiver faulty

Bit 3: Temperature error: $T > +85^{\circ}\text{C}$

Bit 2: Supply voltage too low

Bit 1: PLL unlocked

Bit 0: always "0"

Parameters:

none

Driver files for bus adapter

The disk enclosed with the respective bus adapters contains the following driver files:

.gsd Driver for ProfiBus
.eds Driver for DeviceNet

Kontaktadressen / Contact addresses / Contacts

Deutschland

SensoPart Industriesensorik GmbH
Am Wiedenbach 1
D-79695 Wieden
Tel.: +49 (0) 7665 – 94769 - 0
Fax: +49 (0) 7665 – 94769 - 765
info@sensopart.de
www.sensopart.de

Great Britain

SensoPart UK Ltd.
G8 The Arch
48-52 Floodgate Street
GB-Birmingham B5-5SL
Tel.: +44 (0) 1 21 / 7 72-51 04
Fax: +44 (0) 1 21 / 7 72-51 26
gb@sensopart.com
www.sensopart.com

France

SensoPart France SARL
11, rue Albert Einstein
Espace Mercure
F-77420 Champs – Marne la Vallée
Tel.: +33 (0) 1 64 73 00 61
Fax: +33 (0) 1 64 73 10 87
info@sensopart.fr
www.sensopart.com

USA

SensoPart Inc.
1690 Woodlands Drive
Suite 224
Maumee, OH 43537, USA
Tel.: +1 866 282 - 7610
Fax: +1 419 897 - 7991
usa@sensopart.com
www.sensopart.com