

OD Max: Highly precise distance measurement

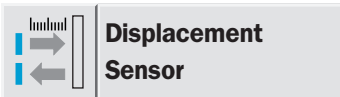
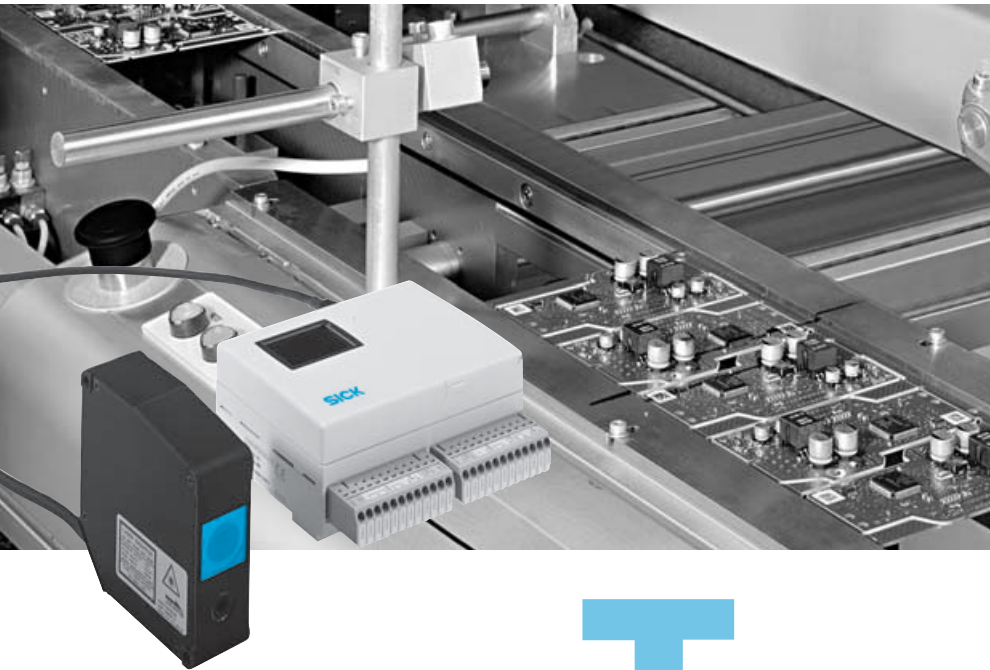

Stocked, Distributed, and Supported by

SENSORS
INCORPORATED

507 Kelsey Street • Delano, MN 55328
Phone 763-972-1040 Fax 763-972-1041
Toll Free 888-920-0939
Sensorsincorporated.com

The OD Max is an highly precise sensor system for distance measurement being made up of one or two sensor heads and an amplifier unit. The – compared to existing systems – by factor 10 improved accuracy of the system (to $\pm 0.1\%$ of full scale) opens up unknown possibilities within the sector of sensor and automation technology. Apart from the sheer measurement of the distance also a variety of different applications like e.g. measurement of the

thickness or the evenness can be achieved. This is due to the in the system integrated arithmetical functions.

Based on the highly sophisticated CMOS technology and the fast measuring frequency in combination with the automatic setting of the sensitivity the system is capable of reliably measuring almost all materials. Therefore the sensor can also be used in most branches. Possible industries are for example the automotive, electronics, semiconductor, robotics and automation industry. Additionally to this the area of application within those branches is also diverse. For example process control, quality control or the identification of parts are possible applications.

In terms of the sensor heads three variants with the medium working distances of 30 mm, 85 mm or 350 mm are available. Regarding the amplifier unit a PNP and a NPN version are available.

SICK

	Measurement range
	30 ± 5 / 85 ± 20 /
	350 ± 100 mm
Displacement Sensor	

- Laser Technology
- CMOS Technology: object independent measuring from shiny to dark
- High measurement accuracy
- High-End-System: 1 or 2 sensor heads per amplifier unit
- 4 analogue outputs and 5 switching outputs
- RS 232C interface

Dimensional drawing

OD30-05T1 OD85-20T1

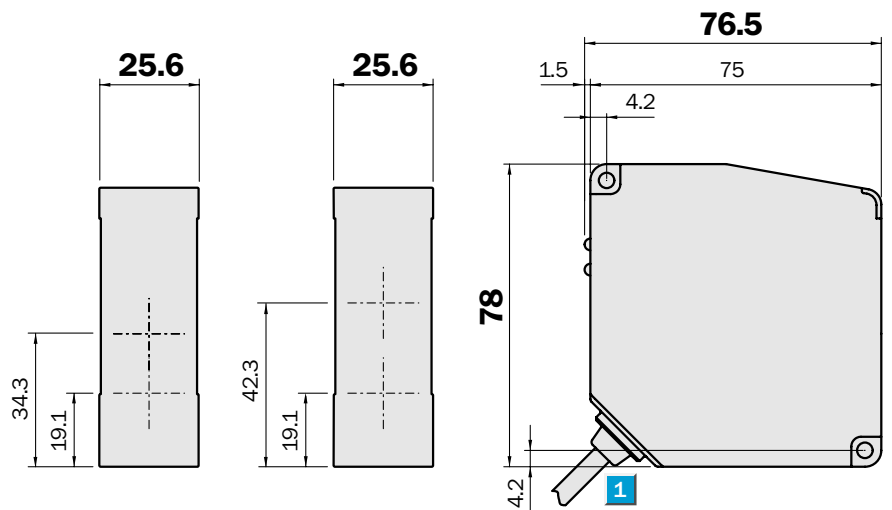

OD350-100T1

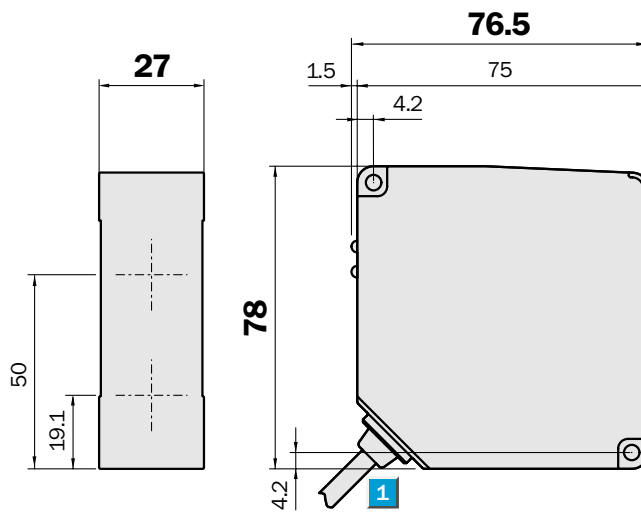

- 1** Cable Ø 5 mm/0.5 m with 10-pin connector
- 2** Distance indicator LED
- 3** Laser on LED

Adjustments possible

All types

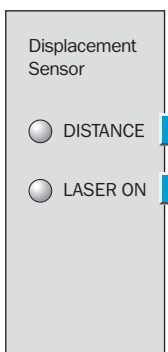

Connection types

All types 10-pin

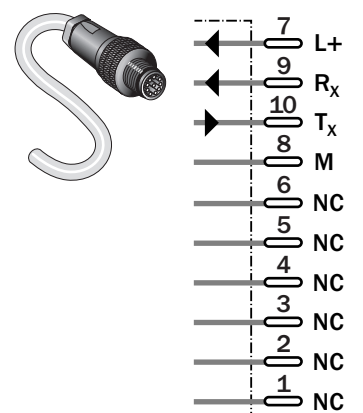

Accessories
Connectors

Technical Data		OD	30-05T1	85-20T1	350-100T1						
Measuring range	30 ± 5 mm		■								
	85 ± 20 mm			■							
	350 ± 100 mm				■						
Light source	Red laser diode 2 (II) ¹⁾		■	■	■						
Measuring frequency	10 kHz		■	■	■						
Resolution ²⁾	1 µm		■								
	5 µm			■							
	50 µm				■						
Reproducibility ³⁾	3 µm		■								
	15 µm			■							
	150 µm				■						
Accuracy ⁴⁾	± 10 µm		■								
	± 40 µm			■							
	± 200 µm				■						
Supply voltage V _S	Supplied from the amplifier unit		■	■	■						
Temperature drift	±0.01 % FS ⁵⁾ /°C		■	■	■						
Enclosure rating	IP 67		■	■	■						
VDE protection class	III		■	■	■						
Ambient temperature T _A	Operation -10 °C ... +45 °C ⁶⁾		■	■	■						
	Storage -20 °C ... +60 °C		■	■	■						
Ambient light limit	max. 3.000 lx (fluorescent light)		■	■	■						
	max. 10.000 lx (sun light)		■	■	■						
Vibration resistance	10/s ... 55/s ⁷⁾		■	■	■						
Shock resistance	50 G (500 m/s ²)		■	■	■						
Weight	250 g (including 50 cm cable)		■	■	■						
Material	Sensor head housing: Diecast aluminium		■	■	■						
Cable extension	0.5 m pig tail with connector ⁸⁾		■	■	■						

- 1) Wavelength 650 nm, max. output 1 mW
- 2) Averaging: 256 measurements
object: white ceramic
distance range: average distance
- 3) With constant conditions of the environment

- 4) Equivalent ± 0.1 % of Full Scale for 6 ... 90 % remission
- 5) Full Scale:
OD30-05T1 = 10 mm
OD85-20T1 = 40 mm
OD350-100T1 = 200 mm

- 6) Non-condensing
- 7) Double amplitude 1.5 mm, 2 h for XYZ axes
- 8) Extendable by cable to max. 10 m

OD30-05T1: Lightspot diameter

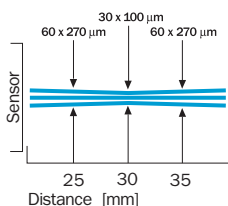

OD85-20T1: Lightspot diameter

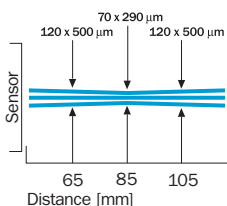

OD350-100T1: Lightspot diameter

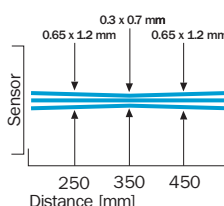

Order information

Type	Order no.
OD30-05T1	6028959
OD85-20T1	6028958
OD350-100T1	6028957

Technical Data		AOD-	P1	N1								
In- and outputs	PNP											
	NPN											
Response time ¹⁾	0.5 ms											
Output rate	10 kHz											
Supply voltage V_S	12 ... 24 V DC ± 10 %											
Power consumption ²⁾	6 W											
Outputs												
2 Analogue voltage outputs ³⁾	-5 ... + 5 V ⁴⁾											
2 Analogue current outputs ³⁾	4 ... 20 mA ⁵⁾											
5 Switching outputs ⁶⁾	Max. 100 mA/24 V DC ⁷⁾											
2 Alarm outputs	To indicate failed measurements											
Data interface	RS 232C (male)											
Inputs												
3 Bank inputs	External memory bank selection											
3 Hold inputs	Holding the measurement/Laser off											
2 Zero reset inputs	To reference the measurement											
Additional features												
	Arithmetical calculations											
	Averaging functions											
	Frequency filters											
	Autom./manual sensitivity setting											
	Timer functions											
	8 Memory banks											
	Hold functions											
Display type	LCD colour display											
Enclosure rating	IP 20											
VDE protection class	III											
Ambient temperature T_A	Operation -10 °C ... +45 °C ⁸⁾											
	Storage -20 °C ... +60 °C											
Vibration resistance	10/s ... 55/s ⁹⁾											
Shock resistance	20 G (196 m/s ²)											
Weight	240 g (including terminal board)											
Material	Housing	Polycarbonate										
	Terminal board	Nylon 66										
Connection type	Terminal board											

¹⁾ Without averaging and manually selected sensitivity
²⁾ When connected with 2 sensor heads. Including analogue current output.
³⁾ 1 for each sensor head, or 1 for the calculation result.

⁴⁾ Output impedance 100 Ω, resolution 1 mV
⁵⁾ Load impedance max. 300 Ω, resolution 1.5 µA
⁶⁾ For the calculation result

⁷⁾ Residual voltage max. 1.8 V
⁸⁾ Non-condensing
⁹⁾ Double amplitude 1.5 mm, 2 h for XYZ axes

Order information	
OD Max™ Amplifier unit	
Type	Order no.
AOD-P1	6028960
AOD-N1	6028961

Accessories, extension cable		
Type	Order no.	Cable length
DSL-1210-G02M	6028943	2 m
DSL-1210-G05M	6028944	5 m

Displacement sensor OD Max, amplifier unit

Measurement range
 $30 \pm 5 / 85 \pm 20 /$
 $350 \pm 100 \text{ mm}$

Displacement Sensor

- Laser Technology
- CMOS Technology: object independent measuring from shiny to dark
- High measurement accuracy
- High-End-System: 1 or 2 sensor heads and amplifier unit
- 4 analogue outputs and 5 switching outputs
- RS 232C interface

Dimensional drawing

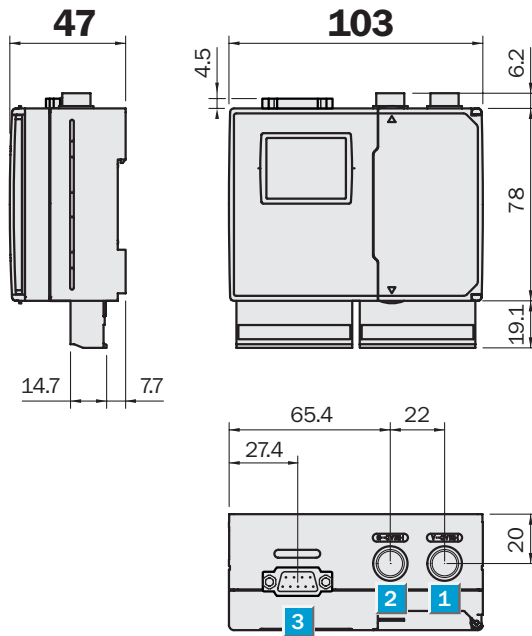

Adjustments possible

AOD-P1
AOD-N1

- 1 Sensor head A connection port
- 2 Sensor head B connection port
- 3 RS 232C interface
- 4 LCD display
- 5 Operation panel
- 6 DIN rail
- 7 Terminal board (detachable)

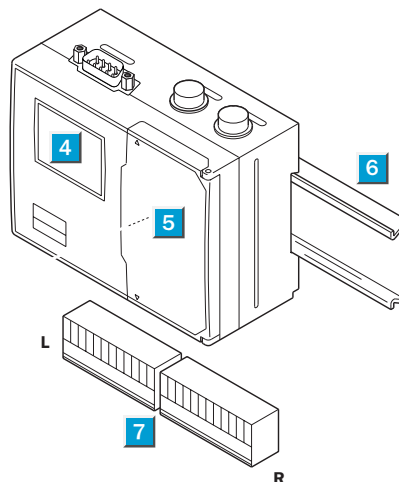

Connection terminal board

AOD-P1
AOD-N1

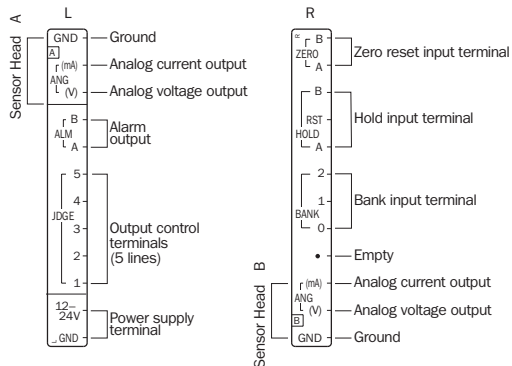

Connector pinning RS 232C

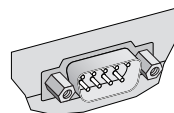

Female connector, 9-pin

- 1 DCD – Data Carrier Detect
- 2 RXD – Receive Data
- 3 TXD – Transmit Data
- 4 DTR – Data Terminal Ready
- 5 SG – Signal Ground
- 6 DSR – Data Set Ready
- 7 RTS – Request to Send
- 8 CTS – Clear to Send
- 9 RI – (Ring Indicator)

Accessories

Connectors

Australia

Phone +61 3 9497 4100
1800 33 48 02 – tollfree
E-Mail sales@sick.com.au

Belgium/Luxembourg

Phone +32 (0)2 466 55 66
E-Mail info@sick.be

Brasil

Phone +55 11 5091-4900
E-Mail sac@sick.com.br

Ceská Republika

Phone +420 2 57 91 18 50
E-Mail sick@sick.cz

China

Phone +852-2763 6966
E-Mail ghk@sick.com.hk

Danmark

Phone +45 45 82 64 00
E-Mail sick@sick.dk

Deutschland

Phone +49 (0)2 11 53 01-250
E-Mail info@sick.de

España

Phone +34 93 480 31 00
E-Mail info@sick.es

France

Phone +33 1 64 62 35 00
E-Mail info@sick.fr

Great Britain

Phone +44 (0)1727 831121
E-Mail info@sick.co.uk

India

Phone +91-22-2822 7084
E-Mail info@sick-india.com

Italia

Phone +39 02 27 40 93 19
E-Mail info@sick.it

Japan

Phone +81 (0)3 3358 1341
E-Mail info@sick.jp

Nederlands

Phone +31 (0)30 229 25 44
E-Mail info@sick.nl

Norge

Phone +47 67 81 50 00
E-Mail austefjord@sick.no

Österreich

Phone +43 (0)22 36 62 28 8-0
E-Mail office@sick.at

Polska

Phone +48 22 837 40 50
E-Mail info@sick.pl

Republic of Korea

Phone +82-2 786 6321/4
E-Mail kang@sickkorea.net

Republika Slovenija

Phone +386 (0)1-47 69 990
E-Mail office@sick.si

Russia

Phone +7 95 775 05 30
E-Mail info@sick-automation.ru

Schweiz

Phone +41 41 619 29 39
E-Mail contact@sick.ch

Singapore

Phone +65 6744 3732
E-Mail admin@sicksgp.com.sg

Suomi

Phone +358-9-25 15 800
E-Mail sick@sick.fi

Sverige

Phone +46 8 680 64 50
E-Mail info@sick.se

Taiwan

Phone +886 2 2365-6292
E-Mail sickgrc@ms6.hinet.net

Türkiye

Phone +90 216 388 95 90 pbx
E-Mail info@sick.com.tr

USA/Canada/México

Phone +1(952) 941-6780
1 800-325-7425 – tollfree
E-Mail info@sickusa.com

More representatives and agencies
in all major industrial nations at
www.sick.com