

## CET-AR – Sicherheitsschalter der neuesten Generation CET-AR – a Safety Switch of the Newest Generation

- ▶ Sicherheitsschalter mit Zuhaltung und Zuhaltungsüberwachung
- ▶ Integrierte Auswerteelektronik
- ▶ Transpondercodierung (RFID)
- ▶ Robustes Metallgehäuse
- ▶ Hohe Zuhaltkräfte bis zu 5000 N
  
- ▶ *Safety switch with guard locking and guard lock monitoring*
- ▶ *Integrated evaluation electronics*
- ▶ *Transponder coding (RFID)*
- ▶ *Robust metal housing*
- ▶ *High locking force up to 5000 N*

Der CET-AR ist ein Sicherheitsschalter mit überwachter Zuhaltfunktion und integrierter Auswerteelektronik. Er kann als Einzelgerät oder in einer Reihenschaltung betrieben werden. Der Schalter ist kompatibel zur CES-AR Familie und kann in Kombination mit dem CES-AR und dem Sicherheitssystem MGB betrieben werden.

Der CET-AR wird über M12 Steckverbinder angeschlossen. Die zwei Sicherheitsausgänge können direkt an Antriebe, nachgeschaltete Sicherheitsrelais oder sichere Steuerungen angeschlossen werden.

Optional lassen sich eine Starttaste und ein Rückführkreis anschließen. Dadurch ist der CET-AR eine vollwertige, dezentrale Sicherheitslösung (PLe nach EN ISO 13849-1). Vier Status-LEDs, davon zwei frei ansteuerbar, sorgen für den schnellen Überblick.

### Ihre Vorteile

- ▶ Reihenschaltung von bis zu 20 Geräten
- ▶ Performance Level e nach EN ISO 13849-1
- ▶ Geeignet für schwere Türen
- ▶ Hohe Manipulationssicherheit
- ▶ Hohe Schutzart IP67
- ▶ Detaillierte Diagnose mit zwei LEDs (DIA/STATE)
- ▶ Zusätzlich zwei frei belegbare LEDs

Lieferbar ab sofort



The CET-AR is a safety switch with monitored guard locking device and integrated evaluation electronics. It can be operated as a single device or in a series connection. The switch is compatible to the CES-AR series and can be operated in combination with the CES-AR and the safety system MGB.

The CET-AR is connected to M12 plug connectors. The two safety outputs can directly be attached to drives, downstream safety relays or safe control systems.

A start button and a feedback loop can optionally be connected. Thus, the CET-AR is a complete and local safety solution (PLe acc. to EN ISO 13849-1). Four status LEDs - two of them can be connected according to the customer needs - provide a fast overview.

### Your advantages

- ▶ Series connection of up to 20 devices
- ▶ Performance Level e acc. to EN ISO 13849-1
- ▶ Suitable for heavy doors
- ▶ High protection against tampering
- ▶ High degree of protection IP67
- ▶ Detailed diagnostics with two LEDs (DIA/STATE)
- ▶ Two additional LEDs for free assignment

Available from now

More than safety.



**SENSORS**  
INCORPORATED

507 Kelsey St. • Delano, MN 55328  
Phone: 763-972-1040 • Fax: 763-972-1041  
Toll Free: 1-888-920-0939  
www.SensorsIncorporated.com

**EUCHNER**



## PRESS RELEASE

Leinfelden, September 2007

### The non-contact guard locking CET - an advanced combination

**Mechanical safety switches with guard locking for monitoring safety guards have been available for many years.**

**With its non-contact guard locking CET, EUCHNER is now breaking new ground and combining non-contact transponder technology with mechanical guard locking.**

Machines and systems that carry out dangerous sequences of movements are fitted with a protective enclosure to protect the operator. If there is a movable safety guard (i.e. safety door) on the access to the machine, this door must be monitored. Safety switches, as the interface between the operator and the safety related part of a control system, are then at the focus of any safety assessment.

For the optimal selection of the necessary switch, the switch's application must be clarified first. If, on stopping the system (or opening the safety door), the operator has direct access to overtraveling machine movements, a safety switch with monitored guard locking is imperative in accordance with EN 1088. In this case the guard locking has a personal protection function.

Safety switches with guard locking are, however, also used on machines to prevent unintentional opening of the door. Although a position switch would reliably stop the system, the production



*Figure 1: Combination of non-contact technology with mechanical guard locking – the non-contact guard locking CET*

process would be interrupted with possible damage to the workpiece and tool. In this case the guard locking has a process protection function.

Mechanical safety switches with guard locking and guard lock monitoring have been proven in use over many years. EUCHNER is well-known on the market as a specialist for safety switches and, along with its proven TZ, TP or STP series, has a broad product range. In recent years, non-contact technology has become increasingly established on the market and is today an integral part of many safety concepts. EUCHNER is also a leader in this area – the non-contact safety system CES based on transponder technology is well-known and well established.

## **The consequence – a combination of non-contact technology with mechanical guard locking**

As a leader in the area of mechanical safety switches with guard locking and in the area of non-contact safety technology, EUCHNER is now combining both with the new read head CET to a non-contact guard locking.

The new CET provides guard locking with guard lock monitoring in accordance with EN1088. Depending on the installed evaluation unit, the switch can be used either for the protection of personnel according to EN 1088 or for process protection.

## **How does the CET work?**

The non-contact guard locking CET consists of two components: the CET actuator and the CET read head.

"The CET actuator is fastened to the moving part of the safety guard. It has a spring-loaded pin; a transponder chip is fitted to the outer end of this pin so that it is protected. Each transponder in an actuator is unique, no two CET actuators have identical coding", explains Dipl.-Ing. Erich Wächter, Product Manager of non-contact safety products at EUCHNER.

The CET is attached to the fixed part of the safety guard. At the end of the insertion slide there is a recess where the read head is installed.

When the safety guard is closed, the CET actuator slides along the insertion slide. During this process the spring-loaded pin on the CET actuator is pressed in. When the door is completely closed, the pin engages in the recess on the funnel. As a result the safety guard is locked and cannot be opened.

**Non-contact, monitored guard locking. A contradiction in terms?**

"Not at all", says Erich Wächter. "The CET is based on the principle of transponder technology. EUCHNER has been using this technology successfully for many years in the non-contact safety system CES."

In the guard locked position, the CET actuator's transponder is in the read head's operating distance. Data is transferred between the externally connected CES evaluation unit and the transponder. If the CES evaluation unit connected detects valid transponder data, the two relay safety outputs are switched. The process to be monitored can be started. As long as the data transfer takes place between the transponder and the CES evaluation unit, it is certain that the CET actuator is in the guard locking position. The guard locking is deactivated once the machining cycle has been completed and the dangerous parts of the machine have all stopped. When 24 V DC is applied to the solenoid in the safety switch, a plunger pushes the actuator out of the recess (closed-circuit principle). The actuator leaves the read head's operating distance. As a result, the data transfer to the CES evaluation is interrupted, the safety outputs opened and the power to the drives connected safely interrupted. The safety guard can only be opened if the actuator is out of the recess. Guard locking in accordance with EN 1088 is therefore provided.

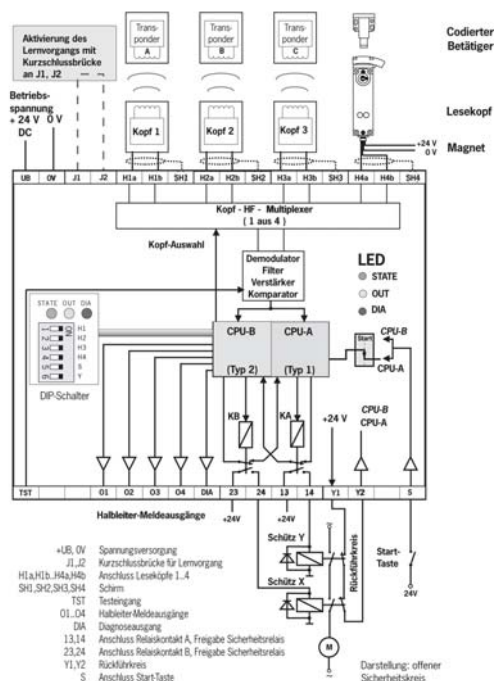

Figure 2: Wiring and block diagram CET

applied to the solenoid in the safety switch, a plunger pushes the actuator out of the recess (closed-circuit principle). The actuator leaves the read head's operating distance. As a result, the data transfer to the CES evaluation is interrupted, the safety outputs opened and the power to the drives connected safely interrupted. The safety guard can only be opened if the actuator is out of the recess. Guard locking in accordance with EN 1088 is therefore provided.

### **A switch for maximum safety – protection of personnel up to category 3**

Due to its principle of operation, the CET provides a high level of safety. Mechanical safety switches with guard locking that do not have electronic, dynamic monitoring cannot achieve safety category 3 in accordance with EN 954-1 without failure exclusion. To achieve category 3, it would then even be necessary to use two mechanical safety switches (e. g. with and without guard locking).

Using the non-contact guard locking CET, costs can certainly be saved here. The CET actuator's transponder data are polled dynamically by the evaluation unit. For the evaluation unit this means: as long as the transponder is in the read head's operating distance, the safety guard is locked. Faults, for example an interruption in the data transmission, are safely detected immediately. As a result, the CET in combination with the corresponding evaluation unit CES is suitable as guard locking for the personal protection in safety category 3.

### **Category 4 for process protection**



Guard locking is used for process protection when monitoring systems without "overtraveling" machine movements. The polling of the position of the safety guard – open or closed – is then the aspect that is actually of safety related significance. On the usage of the CET as guard locking for process protection, the highest safety category, category 4, is even achieved. In this high category, even an accumulation of faults must not result in the loss of safety. For this reason, the CET must be fitted with the insertion slide pointing down or sideways to monitor the door position (door open or locked) in category 4. Even if the actuator breaks, the fault will be detected, as with this type of attachment the broken piece would fall out of the recess. As a result, even then the data transmission between read head and actuator will be reliably interrupted.

*Figure3: Category 4 for process protection if the CET is fitted with the insertion slide pointing downward.*

## Tamper protection – the never-ending story

How tamper-proof must a switch be? Every organisation operating machinery must address this question; the answer will vary depending on the application.

If maximum protection against tampering is required, the non-contact guard locking CET is the perfect solution. With the CES unicode evaluation unit, a unique CET actuator is detected. Prior to setup, it is necessary to teach-in the related transponder on the unicode evaluation unit. Tampering with a second CET actuator with the safety guard open is then not possible. The CET is also fastened using safety screws. As a result, actuators that are already fitted cannot be removed from the safety guard – an additional protection against tampering.



Figure 4: CET with double insertion slide for use, for instance, on indexing tables

However, there are applications in which the usage of several actuators in combination with a single CET read head is required.

On indexing tables, e. g., there are different machining areas. It is only allowed to start a work step on one of these areas once the table is in the protected position. For this application, EUCHNER provides a CES multicode evaluation unit for the CET. Unlike evaluation units with unicode detection, on the multicode unit a specific code is not requested, instead it is only checked whether the actuator is of a type that can be detected by the system.

EUCHNER has developed a CET with "double insertion slide" for such applications. This CET can be approached by the actuator from two sides, or "missed out".

## All the advantages at a glance

In summary, the new EUCHNER non-contact guard locking CET has the following advantages:

- Non-contact, monitored guard locking
- Personal protection up to safety category 3, process protection up to category 4
- High protection against tampering

Furthermore, the basic advantages of EUCHNER safety switches also apply to the CET, specifically

- A sturdy die-cast zinc housing for harsh ambient conditions
- High degree of freedom
- Low wiring effort
- Or even a connection option for AS-Interface Safety at Work

### **System solutions are in demand**

The non-contact guard locking CET is part of the overall CES system. Up to four different EUCHNER CES read heads or switches with or without guard locking can be connected to the CES evaluation units in mixed operation.

The CES system is a non-contact safety concept with many ideas and visions. The future of non-contact transponder technology has only just begun.

**EUCHNER – More than safety.**

[Characters with blanks: 9,171]

## Short profile: EUCHNER GmbH + Co. KG

*EUCHNER GmbH + Co. KG in Leinfelden is an international family owned enterprise and employs more than 400 persons worldwide. Eleven sales subsidiaries out of which seven are in Europe, two in Asia and two in North and South America cover the globe along with 23 authorized sales offices. The company is managed by the brothers Michael and Stefan Euchner.*

*Mechanical switches have been developed at EUCHNER for more than 50 years. These devices are used primarily in machine tool manufacturing. The company has a leading position in safety products. EUCHNER safety switches monitor the position of safety guards on machines and systems.*

Further information on the company is available on the Internet at [www.euchner.de](http://www.euchner.de)

### **EUCHNER GmbH + Co. KG**

Postfach 10 01 52  
D-70745 Leinfelden-Echterdingen  
Tel. +49-(0)711-7597-0  
Fax +49-(0)711-753316  
[www.euchner.de](http://www.euchner.de)  
[info@euchner.de](mailto:info@euchner.de)

### **Productmanager Safety**

Dipl.-Ing.  
Erich Wächter  
Tel. +49-(0)711-7597 – 302  
Fax +49-(0)711-7597 – 303  
[erich.waechter@euchner.de](mailto:erich.waechter@euchner.de)

### **Presscontact**

Dipl.-Betriebsw. (FH)  
Stephanie Müller  
Marketing  
Tel. +49-(0)711-7597–275  
Fax +49-(0)711-7597–385  
[stephanie.mueller@euchner.de](mailto:stephanie.mueller@euchner.de)

# **SENSORS**

## **INCORPORATED**

507 Kelsey St. • Delano, MN 55328  
Phone: 763-972-1040 • Fax: 763-972-1041  
Toll Free: 1-888-920-0939  
[www.SensorsIncorporated.com](http://www.SensorsIncorporated.com)