

Stocked, Distributed, and Supported by

SENSORS
INCORPORATED

507 Kelsey Street • Delano, MN 55328
Phone 763-972-1040 Fax 763-972-1041
Toll Free 888-920-0939
Sensorsincorporated.com

Datasheet

Features

- High Sensitivity and high SNR Performance Linear CCD
- 12288 Resolution with 5 μm Square Pixels
- 100% Aperture, Built-in Anti-blooming, No Lag
- Camera Link[®] Data Format (Medium or Full Configuration)
- Up to 24.7 kHz Line Rate
- High Data Rate: Up to 320 Mpixels/s
- Flexible and Easy to Operate via Serial Control Lines:
 - Gain: up to 45 dB in steps of 0.035 dB
 - Output Mode: 8, 10, 12-bit Data on 4 or 8 Taps
 - Offset (for Contrast Expansion)
 - Trigger Mode: Free-run or External Trigger Modes
- Flat-field Correction (Lens and Light Non-uniformity Correction)
- Automatic Tap Balancing
- Single Power Supply: DC 12 to 24V
- Very Compact Design: 76 x 76 x 56 mm (w, h, l)
- High reliability, RoHS, CE and FCC Compliant
- M72 x 0.75 Mount Adapter



Description

This 12k CCD based line scan camera, the AViVA M8, takes full advantage of all the features that make the AViVA family successful (reliability, compactness, accuracy) with improved performance:

- Increased Sensitivity, Speed, Resolution and Non-uniformity
- Better Electronic SNR thanks to Optimized Design and Component Selection
- Ease of Use, Automatic Taps Balancing

e2v manages the entire production chain, from the sensor to the camera. The design integrates the very best of e2v experience combining performance with simplicity.

Application

High speed, high resolution, performance and reliability of this camera make it well suited for the most demanding industrial applications (web inspection, document scanning, surface inspection). It is especially well suited to Flat Panel Display and Printed Circuit Board inspection (PCB) or high speed document scanning.

Visit our website: www.e2v.com
for the latest version of the datasheet

1. Typical Performances

Test conditions:

- Maximum data rate (8 × 40 MHz)
- Light source 3200K with BG38 filter 2 mm thickness
- LSB are given for 12-bit depth configuration

Table 1-1. Typical Performances

Parameter	Value				Unit
Sensor Characteristics					
Resolution	12288				pixels
Pixel size	5 × 5				µm
Line length	61.4				mm
Maximum line rate	24.7				kHz
Anti-blooming	× 100				
Radiometric Performances (Maximum Pixel Rate, T_{amb} = 25°C)					
Bit depth	8, 10 or 12				Bit
Spectral range	250 to 1100				nm
Non-linearity	1				%
Gain	-18 dB	-9 dB	0 dB	9 dB	
Dynamic range	1990 :1	1053 :1	263 :1	94 :1	
Integrated response	23	63	171	465	LSB/nj/cm ²
PRNU p-p (at FSR/2)	2				%
FPN p-p (at minimum gain)	<3				LSB
FTM at Nyquist	40				%
Mechanical and Electrical Interface					
Size (w × h × l)	76 × 76 × 56				mm
Lens mount	M72 × 0.75				–
Sensor alignment (x, y and z axes)	±0.05				mm
Power supply	DC, single 12 to 24				V
Power dissipation	14				W
Weight	505				g

Table 1-1. Typical Performances (Continued)

Parameter	Value	Unit
Operating temperature	0 to 55 (non-condensing)	°C
Storage temperature	-40 to 70 (non-condensing)	°C
Spectral Response		

2. Camera Description

Figure 2-1. Sensor Block Diagram

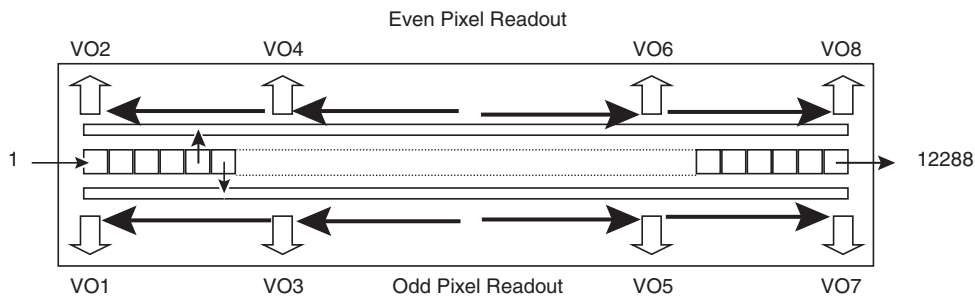
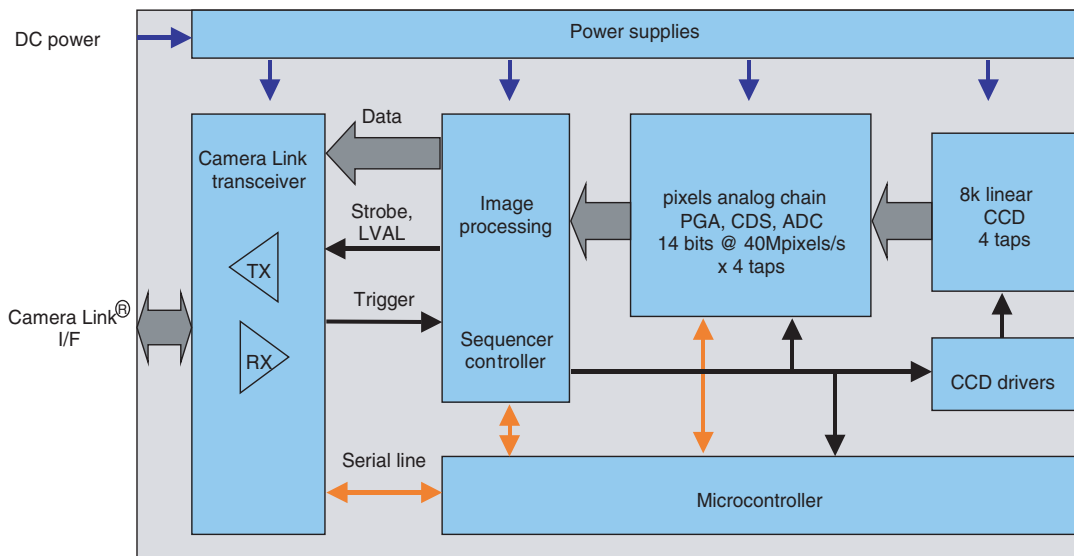

Figure 2-2. Camera Block Diagram



The camera is based on an eight-tap linear CCD sensor. Therefore, eight analog chains process pixels output of the linear sensor. The *CCD signal processor* encompasses the correlated double sampling (CDS), the dark level correction (dark pixel clamping) and the analog-to-digital conversion in 14 bit. Digital data are then processed in the FPGA (flat field correction, contrast expansion, automatic taps balancing and test pattern generation).

Data are output simultaneously on eight channels (at 8×40 MHz) as follow:

Tap #1: pixel 1, 3, 5, ..., 3071 Tap #2 : pixel 2, 4, 6, ..., 3072

Tap #3: pixel 3073, 3075, 3077, ..., 6143 Tap #4 : pixel 3074, 3076, 3078, ..., 6144

Tap #5: pixel 9215, 9213, 9211, ..., 6145 Tap #6 : pixel 9216, 9214, 9212, ..., 6146

Tap #7: pixel 12287, 12285, 12283, ..., 9217 Tap #8 : pixel 12288, 12286, 12284, ..., 9217

In case of *four output channels* mode, Taps are multiplexed two by two (Tap#1 with Tap#2, Tap#3 with Tap#4, etc.). The data frequency is 4×80 MHz (f/1 setting).

The functional interface (data and control) is provided by the Camera Link interface. The camera uses the *medium* or *full* configuration of Camera Link standard with DVAL = 1 and FVAL = 0.

3. Standard Conformity

The AViiVA cameras have been tested using the following equipment:

- A shielded power supply cable
- A Camera Link data transfer cable ref. 14B26-SZLB-500-OLC (3M)
- A linear AC-DC power supply

e2v recommends using the same configuration to ensure the compliance with the following standards.

3.1 CE Conformity

The AViiVA cameras comply with the requirements of the EMC (European) directive 89/336/CEE (EN 50081-2, EN 61000-6-2).

3.2 FCC Conformity

The AViiVA cameras further comply with Part 15 of the FCC rules, which states that:

Operation is subject to the following two conditions:

- This device may not cause harmful interference, and
- This device must accept any interference received, including interference that may cause undesired operation

This equipment has been tested and found to comply with the limits for Class A digital device, pursuant to part 15 of the FCC rules. These limits are designed to provide reasonable protection against harmful interference when the equipment is operated in a commercial environment. This equipment generates, uses and can radiate radio frequency energy and, if not installed and used in accordance with the instruction manual, may cause harmful interference to radio communications. Operation of this equipment in a residential area is likely to cause harmful interference in which case the user will be required to correct the interference at his own expense.

Warning: Changes or modifications to this unit not expressly approved by the party responsible for compliance could void the user's authority to operate this equipment.

4. Camera Command and Control

The camera configuration is set through the serial interface. After adjustments, all the parameters may be stored in an embedded E2Prom memory.

4.1 Syntax

Internal camera configurations are activated by write or readout commands.

The command syntax for write operation is:

```
w <command_name> <command_parameters><CR>
```

The command syntax for readout operation is:

```
r <command_name><CR>
```

4.2 Command Processing

Each command received by the camera is processed:

1. The setting is implemented (if valid)
2. The camera returns ">"<return code><CR>

We recommend waiting for the camera return code before sending a new command.

Table 4-1. Camera Returned Code

Return Code	Meaning
>0	(or >"OK": All right, the command will be implemented)
>3	Error bad CRC in command
>16	Command error (Command not recognized or do not exist)
>21	Invalid Command ID (the Command do not exist)
>33	Invalid Access (the receipt of the last command has failed)
>34	Parameter out-of-range (the parameter of the last command send is out-of-range).
>35	Access failure (bad communication between two internal devices)

4.3 List of Commands

Table 4-2. Usual Features

Title	Command	Features
Output Mode	w mode 0	Set 4 output channels, 8-bit, medium configuration
	w mode 1	Set 4 output channels, 10-bit, medium configuration
	w mode 2	Set 4 output channels, 12-bit, medium configuration
	w mode 3	Set 8 output channels, 8-bit, full configuration
	r mode	Get current output mode
Exposure Time	w tint <val>	Set exposure time to <val>, from 1 to 65535 0.1 µs to 6553 µs by 0.1 µs step
	r tint	Get current exposure time
Line Period	w tper <val>	Set line period to <val> from 1 to 65535 0.1 µs to 6553 µs by 0.1 µs step
	r tper	Get current line period
Pre-amp Gain	w pamp <val>	Set pre-amp gain to: 0 (-9 dB), 1 (-6 dB), 2 (-3 dB), 3 (0 dB)
	r pamp	Get current pre-amp gain
Gain	w gain <val>	Set gain from -237 (-8.32 dB) to + 416 (14.6 dB) by step of 0.0351 dB
	r gain	Get current gain
Digital Gain	w.gdig<val>	Set digital gain from 0 to 255
	r gdig	DG (dB) = 20 log(1+val/64)
Offset	w offs <val>	Set global offset from -4096 to +4095 in 12 bits LSB
	r offs	Get global offset
Synchronisation Mode	w sync 0	Set "Free run" mode
	w sync 1	Set "Triggered mode with exposure time setting"
	w sync 2	Set "Triggered mode with maximum exposure time"
	w sync 3	Set "Triggered mode with exposure time controlled by one signal"
	w sync 4	Set "Triggered mode with exposure time controlled by two signals"
	r sync	Get current Synchronisation mode
Signal Source	w srce 0	Set signal source to CCD sensor
	w srce 1	Set signal source to pattern (Note:)
	r srce	Get current signal source
Flat Field Correction	w ffc 0	Disable Flat Field Correction
	w ffc 1	Enable Flat Field Correction
	r ffc	Get current FFC status
Flat Field Correction (FFC) adjustment	w ffad 0	Disable FFC adjustment
	w ffad 1	Enable FFC adjustment
	r ffad	Get FFC adjustment state

Table 4-2. Usual Features (Continued)

Title	Command	Features
Target FFC adjustment	w tfad val	Set the FFC adjustment target value val (0 to 4095 even in 8 or 10-bit mode)
	r tfad	Get the FFC adjustment target value
Flat Field Calibration (Offset)	w calo 1	Start Flat Field calibration; OnePush button (auto disable once finished)
	w calo 0	Abort Flat Field calibration
	r calo	Get the Flat Field calibration status: 1 if running, 0 when finished
Flat Field Calibration (Gain)	w calg 1	Start Flat Field calibration; OnePush button (auto disable once finished)
	W calg 0	Abort Flat Field calibration
	r calg	Get the Flat Field calibration status: 1 if running, 0 when finished
Flat Field Reset (Offset)	w rsto 0	Clear Offset Flat Field Coefficients to 0
Flat Field Reset (Gain)	w rstg 0	Set Gain Flat Field coefficients to 1
FFC Bank	w sffc <val>	Save current FFC into FFC bank number <val> (1 to 4)
	w rffc <val>	Load current FFC from FFC bank number <val> (1 to 4)
	r rffc	Get the current FFC bank used (saved or loaded)
Taps Balance	w balo 1	Start offset <i>Taps balance</i> ; OnePush button (auto disable once finished)
	w balo 0	Abort offset <i>Tap balance</i>
	r balo	Get the offset <i>Tap balance</i> status : 1 if running, 0 when finished
	w balg 1	Start gain <i>Tap balance</i> ; OnePush button (auto disable once finished)
	w balg 0	Abort gain <i>Tap balance</i>
	r balg	Get the gain <i>Tap Balance</i> status: 1 if running, 0 when finished
Taps Balance bank	w sbal <val>	Save current <i>Tap Balance</i> into bank number <val> (1 to 4)
	w rbal <val>	Load current <i>Tap Balance</i> from bank number <val> (0 to 4) Bank 0 = factory settings
	r rbal	Get the current <i>Tap Balance</i> bank used (saved or loaded)
ModelName	r mdnm	Get camera model name
Camera ID	r idnb	Get camera ID
Customer ID	w cust <idstr>	Set customer ID to <idstr> (max 50 bytes)
	r cust	Get customer ID Return <idstr>
Software Version	r vers	Get the camera software version
Dump	r dump	Get full camera configuration with the format: idnb AT71... fing 5 fga1 120

Table 4-2. Usual Features (Continued)

Title	Command	Features
Configuration	w scfg <val>	Save current configuration into bank number <val> (1 to 4)
	w rcfg 0	Load current configuration from factory bank (0)
	w rcfg <val>	Load current configuration from bank number <val> (1 to 4)
	w rcfg 5	Load current configuration from integrator bank (5).
	r rcfg	Get the current configuration bank used (saved or loaded)

Note: The test pattern must look like the following image.



Table 4-3. Advanced features

Title	Command	Features
Gain Adjustment	w fga<i> <val>	Set gain adjustment for Tap#<i> (1 to 8), from -128 (-0.26 dB) to 127 (0.26 dB), step 0.0021 dB
	r fga<i>	Get gain adjustment for Tap#<i> (1 to 8)
Clamp Adjustment	w off<i> <val>	Set clamp adjustment for Tap#<i> (1 to 8), from -128 to 127 (12-bit LSB)
	r off<i>	Get clamp adjustment for Tap#<i> (1 to 8)
Flat Field Coefficients (Offset)	w ffco <addr> <nbrval> <val> ...[crcval]	Write <nbrval> coefficients starting from the <addr> address.If [crcval] is added, the crc value is computed on the all the<val>.<addr> starts from 1. <val> is signed. <nbrval> is between 1 and 10
	r ffco <addr> <nbrval> [crcreq]	Read <nbrval> coefficients starting from <addr> address.If [crcreq] is equal to 1, the crc will be calculated on the <val>. <nbrval> is between 1 and 10. Output is : <val> ...[crcval]
Flat Field coefficients (Gain)	w ffcg <addr> <nbrval> <val> ... [crcval]	Write <nbrval> coefficients starting from the <addr> address. If [crcval] is added, the crc value is computed on the all the <val>.<addr> starts from 1
	r ffcg <addr> <nbrval> [crcreq]	Read <nbrval> coefficients starting from <addr> address. If [crcreq] is equal to 1, the crc will be calculate on the outputed value. Output is : <val> ...[crcval]
VendorName	r vdnm	Get camera vendor name
Status	r stat	Get camera status

Table 4-3. Advanced features

Title	Command	Features
Baudrate	w baud 1	Set CL RS232 baudrate to 9600 Bds (default value)
	w baud 2	Set CL RS232 baudrate to 19200 Bds
	w baud 6	Set CL RS232 baudrate to 57600 Bds
	w baud 12	Set CL RS232 baudrate to 115200 Bds
	w baud 24	Set CL RS232 baudrate to 230400 Bds (for compatible frame grabber)
	r baud	Get current baudrate

5. Camera Status

The camera status can be read by **r stat** command (see [Table 5-1](#)).

The camera return is a 32-bit value.

Table 5-1. Camera Status

Bit	Status Name	Description
31 .. 22	not used	Set to 0
21 .. 16	internal error	
15 .. 12	not used	Set to 0
11	FFC/Taps balance status	1: in progress 0: disabled or finished
10	FFC/Tap balance underflow	Updated after each calibration operation 1: output level is too high during calibration 0: calibration is well done
9	FFC/Tap balance overflow	Updated after each calibration operation 1: output level is too low during calibration 0: calibration is well done
8	not used	Set to 0
7	settings change	1: states that at least one parameter has been modified and might be saved. Set to 0 during save or restore operation
6	Tap Balance change	
5	FFC change	
4 .. 2	not used	Set to 0
1	Trigger too fast	set to 1 if trigger too fast, else 0
0	Waiting for trigger	Set to 1 if no trigger in <i>external trigger</i> mode

6. Flat Field Correction

The Flat Field Correction consist in applying Ax formula to each pixel value. This allows to correct:

- The lens vignetting
- The light source non-uniformity

Note: Pixel offset is automatically calibrated by the camera.

Calibration procedure:

1. Set the camera in the useful configuration.
2. Switch on the light and place a white reference in front of the camera. Be careful, the quality of this reference is important to get a good calibration.
3. Set parameters (light level, exposure time, gain) to get an output level just above saturation.
4. Start Flat Field calibration.
5. If the result is correct save it in FFC user bank.

Optional functionality: FFC adjustment

This functionality may be helpful:

- To balance response between cameras
- To set a camera at a specific output level

Before calibration procedure:

- Enable FFC adjustment function (w ffad 1)
- Specify desired camera level (w tfad desired value)

Then launch FFC calibration.

After calibration, the camera output level should reach the specified level:

Figure 6-1. FCC Output Adjustment

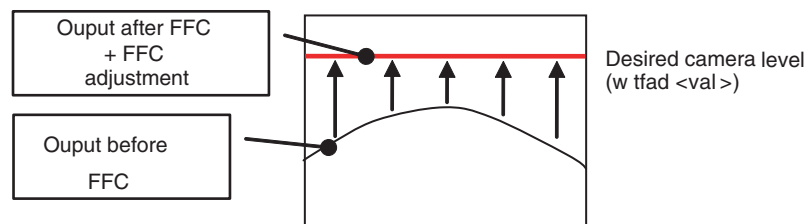

Note: The FFC adjustment target is always specified in a 12 bit value even if camera mode is set in 8 or 10 bits.

Table 6-1. Camera Mode FCC Adjustment

Camera Mode	Camera Level to Reach	FCC Adjustment Target to Specify
12 bit	2048	w tfad 2048
10 bit	512	w tfad 2048 (= 512 x 4)
10 bit	256	w tfad 1024 (= 256 x 4)
8 bit	128	w tfad 2048 (= 128 x 16)
8 bit	200	w tfad 3200 (= 200 x 16)

7. Timing

7.1 Synchronization Mode

Five different modes may be defined by the user. The TRIG1 and TRIG2 signals may be used to trigger external events and control the exposure time.

Table 7-1. Timing Specifications (Typical Values at F/1 Data Frequency)

Label	Description	Typ
td	Trigger to start of exposure delay	0.28 μ s
th	External trigger hold time (minimum pulse high duration)	0.16 μ s
it min	Minimum exposure time duration	1.5 μ s
Lp	Line Period	53.2 μ s
te	End of exposure trigger to real end of exposure time delay	1.42 μ s
ts	End of exposure time to start of exposure time delay	1.7 μ s
rd	End of exposure period to readout delay	0.8 μ s
rp	Readout duration	51.2 μ s
tt	End of readout cycle to end of exposure time	0.45 μ s

7.2 Free-Run Mode (with Exposure Time and Line Period Setting)

Syntax: **w sync 0**

The new line starts automatically and immediately after the previous one. If the programmed line period (per) is lower than the Lp min then the line period is set to the minimum line period. If the programmed exposure time (int) is greater than the programmed line period (per) then the line period is set to exposure time. The read-out time depends on the pixel number and the pixel rate.

Figure 7-1. Free-run Mode Timing Diagram

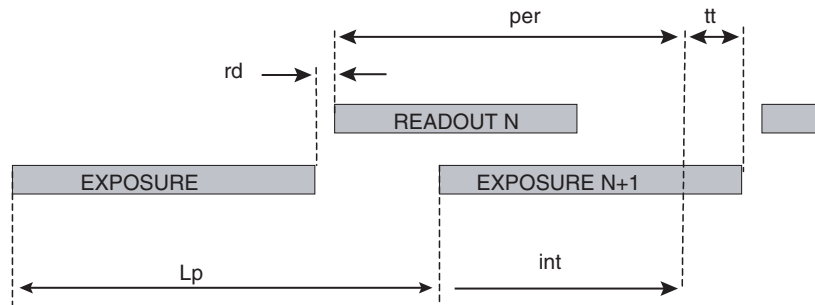

7.3 Triggered Mode with Exposure Time Setting

• Syntax: **w sync 1**

The exposure period starts immediately after the rising edge of the TRIG1 input signal. The exposure time is set through the serial line. This exposure period is immediately followed by a readout period. The readout time depends on the number of pixels and the pixel rate.

Figure 7-2. Triggered Mode Timing Diagram

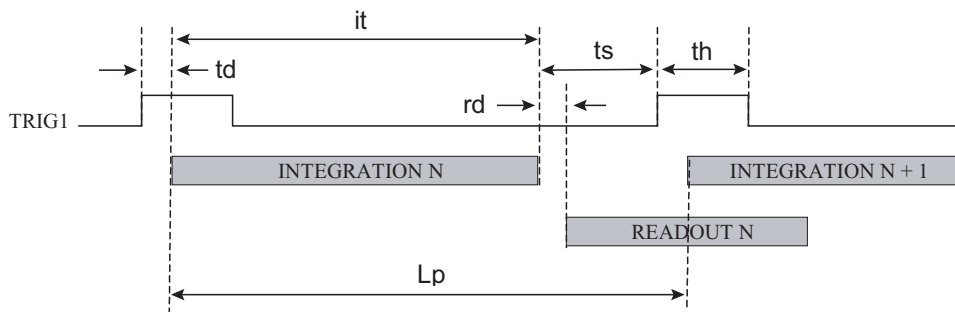

7.4 Triggered Mode with Maximum Exposure Time

Syntax: `w sync 2`

The readout period and the next exposure period start immediately after the rising edge of the TRIG1 input signal.

Figure 7-3. Triggered Readout Mode Timing Diagram

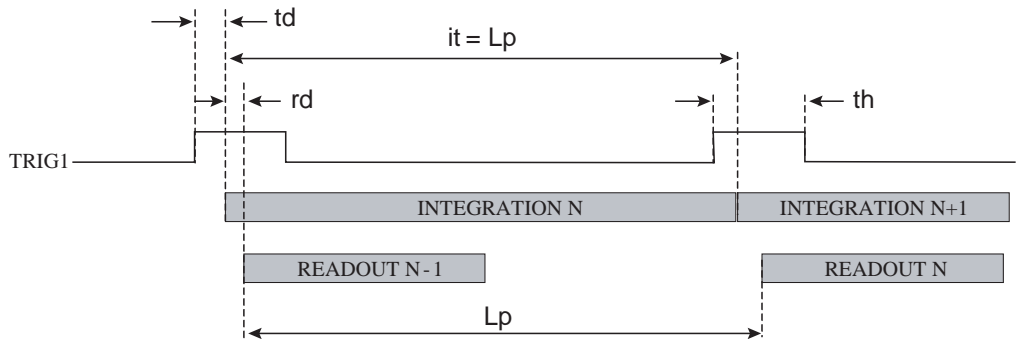

7.5 Triggered Mode with Exposure Time Controlled by One Signal

Syntax: `w sync 3`

The exposure period starts immediately after the falling edge of TRIG1 and stops immediately after the rising edge of TRIG1. This exposure period is immediately followed by a readout period. The readout time depends on the number of pixels and the pixel rate. The pixels are reset while TRIG1 is high.

Figure 7-4. ITC Mode with One Signal Timing Diagram

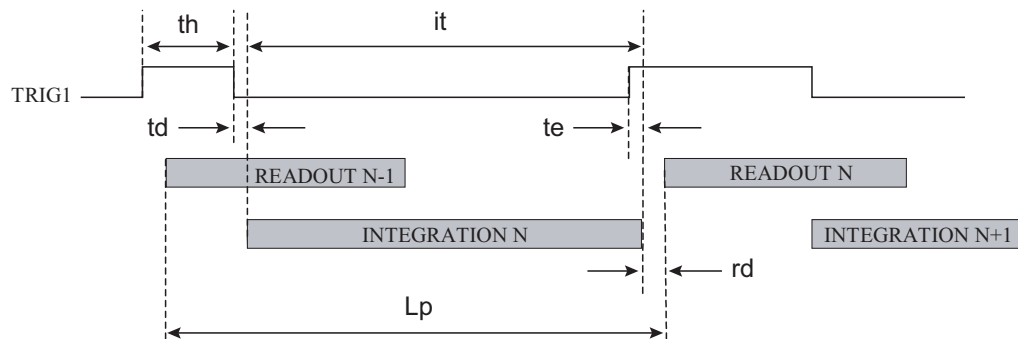

7.6 Triggered Mode with Exposure Time Controlled by Two Signals

Syntax: **w sync 4**

The rising edge of TRIG2 starts the exposure period. The rising edge of TRIG1 stops the exposure period and starts the readout period. The pixels are reset between the rising edge of TRIG1 and the rising edge of TRIG2.

Figure 7-5. ITC Mode with Two Signals Timing Diagram

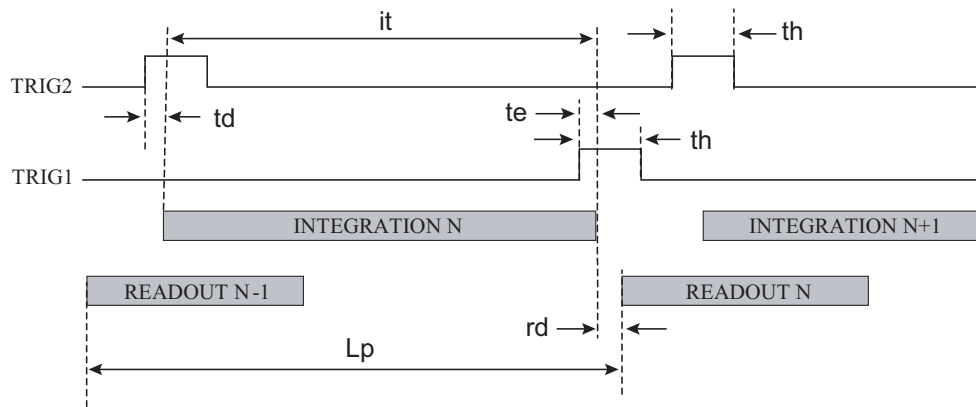

8. Output Data Timing

Table 8-1.

Label	Description	Min	Typ	Max
td	STROBE to synchronized signals delay	-3 ns		+3 ns

Figure 8-1. Timing Diagram

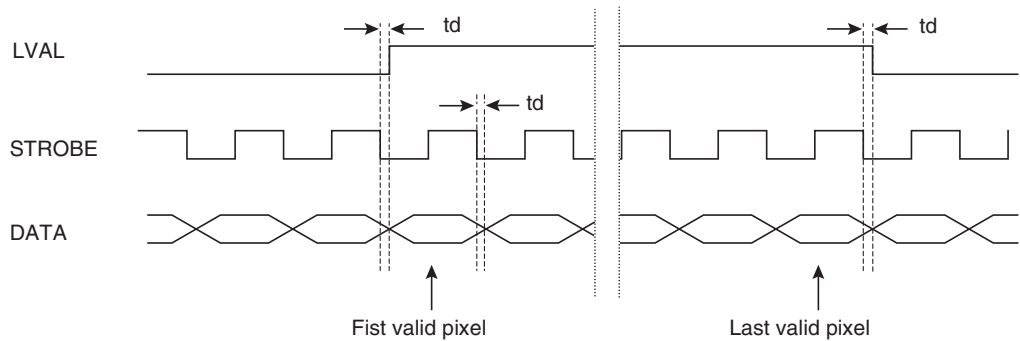

9. Electrical Interface

9.1 Power Supply

It is recommended to insert a two exposure A fuse between the power supply and the camera.

The power supply must provide 25W at power-on sequence.

Signal name	I/O	Type	Description
PWR	P		DC power input : +12V to +24V ($\pm 0.5V$)
GND	P		Electrical and Mechanical ground

Note: I = input, O = output, I/O = bi-directional signal, P = power/ground, NC = not connected

9.2 Camera Control

The Camera Link interface provides four LVDS signals dedicated to camera control (CC1 to CC4). On the camera, two of them are used to synchronize the camera on external events.

Table 9-1.

Signal name	I/O	Type	Description
TRIG1	I	RS664	CC1 - Synchronization input (refer to “Output Data Timing” on page 15)
TRIG2	I	RS664	CC2 - Start exposure period in dual synchronization mode

Note: I = input, O = output, I/O = bi-directional signal, P = power/ground, NC = not connected

9.3 Video Data

Data and Enable signals are provided on the Camera Link interface

Signal name	I/O	Type	Description
OUT1-00 to OUT1-11	O	RS644	Tap#1 Output pixel data (OUT1-00 = LSB, OUT1-11 = MSB)
OUT2-00 to OUT2-11	O	RS644	Tap#2 Output pixel data (OUT2-00 = LSB, OUT2-11 = MSB)
OUT3-00 to OUT3-11	O	RS644	Tap#3 Output pixel data (OUT3-00 = LSB, OUT3-11 = MSB)
OUT4-00 to OUT4-11	O	RS644	Tap#4 Output pixel data (OUT4-00 = LSB, OUT4-11 = MSB)
OUT5-00 to OUT5-11	O	RS644	Tap#5 Output pixel data (OUT5-00 = LSB, OUT5-11 = MSB)
OUT6-00 to OUT6-11	O	RS644	Tap#6 Output pixel data (OUT6-00 = LSB, OUT6-11 = MSB)
OUT7-00 to OUT7-11	O	RS644	Tap#7 Output pixel data (OUT7-00 = LSB, OUT7-11 = MSB)
OUT8-00 to OUT8-11	O	RS644	Tap#8 Output pixel data (OUT8-00 = LSB, OUT8-11 = MSB)
STROBE	O	RS664	Output data clock see “Output Data Timing” on page 15 , data valid on the rising edge
LVAL	O	RS664	Line valid see “Output Data Timing” on page 15 , active high signal

Note: I = input, O = output, I/O = bi-directional signal, P = power/ground, NC = not connected

FVAL, as defined in the Camera Link standard, is not used. FVAL is permanently tied to 0 (low) level.

DVAL is not used. DVAL is permanently tied to one (high) level.

9.4 Serial Communication

The Camera Link interface provides two LVDS signal pairs for communication between the camera and the frame grabber. This is an asynchronous serial communication based on RS-232 protocol.

The serial line configuration is:

- Full duplex/without handshaking
- 9600 bauds (default), 8-bit data, no parity bit, 1 stop bit. The baud rate can be set up to 230,400

Signal name	I/O	Type	Description
SerTFG	O	RS644	Differential pair for serial communication to the frame grabber
SerTC	I	RS644	Differential pair for serial communication from the frame grabber

10. Connector Description

All connectors are on the rear panel.

Note: cables for digital signals must be shielded twisted pairs.

10.1 Power Supply

Camera connector type:Hirose HR10A-7R-6PB (male)

Cable connector type:Hirose HR10A-7P-6S (female)

Table 10-1. Power Supply Connector Pinout

Signal	Pin	Signal	Pin
PWR	1	GND	4
PWR	2	GND	5
PWR	3	GND	6

Figure 10-1. Receptacle Viewed from the Rear Face of the Camera

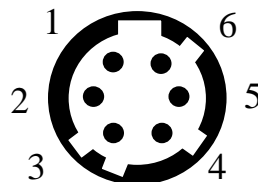

10.2 Camera Link Connector

A standard Camera Link cable must be used to ensure full electrical compatibility.

The camera connector type is MDR-26 (female) ref. 10226-2210VE from 3M.

The cable connector type is a standard Camera Link cable.

Table 10-2. Camera Link Connector Pinout

Signal	Pin	Signal	Pin
GND	1	GND	14
X0-	2	X0+	15
X1-	3	X1+	16
X2-	4	X2+	17
Xclk-	5	Xclk+	18
X3-	6	X3+	19
SerTC+	7	SerTC-	20
SerTFG-	8	SerTFG+	21
CC1-	9	CC1+	22
CC2+	10	CC2-	23
CC3-	11	CC3+	24
CC4+	12	CC4-	25
GND	13	GND	26

11. Mechanical Dimensions

Figure 11-1. Mechanical Drawing

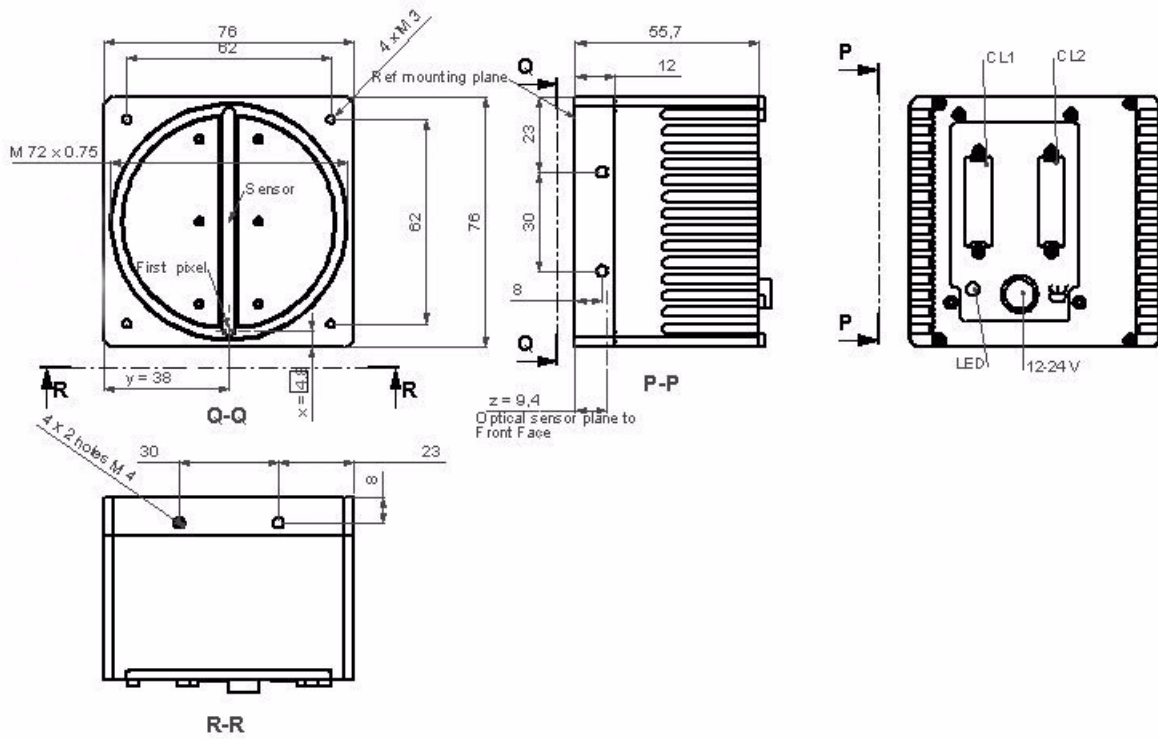

12. Ordering Code

Table 12-1. Ordering Code

Part Number	Description
EV71YUM8CL1205-BA0	Camera, power supply connector and CD-ROM including configuration software and documentation

Note: Lens is not provided



How to reach us

Home page: www.e2v.com

Sales offices:

Europe Regional sales office

e2v ltd

106 Waterhouse Lane
Chelmsford Essex CM1 2QU
England

Tel: +44 (0)1245 493493

Fax: +44 (0)1245 492492

mailto: enquiries@e2v.com

e2v sas

16 Burospace
F-91572 Bièvres Cedex
France

Tel: +33 (0) 16019 5500

Fax: +33 (0) 16019 5529

mailto: enquiries-fr@e2v.com

e2v gmbh

Industriestraße 29
82194 Gröbenzell
Germany

Tel: +49 (0) 8142 41057-0

Fax: +49 (0) 8142 284547

mailto: enquiries-de@e2v.com

Americas

e2v inc

520 White Plains Road
Suite 450 Tarrytown, NY 10591
USA

Tel: +1 (914) 592 6050 or 1-800-342-5338,

Fax: +1 (914) 592-5148

mailto: enquiries-na@e2v.com

Asia Pacific

e2v ltd

11/F.,
Onfem Tower,
29 Wyndham Street,
Central, Hong Kong

Tel: +852 3679 364 8/9

Fax: +852 3583 1084

mailto: enquiries-ap@e2v.com

Product Contact:

e2v

Avenue de Rochepleine
BP 123 - 38521 Saint-Egrève Cedex
France

Tel: +33 (0)4 76 58 30 00

Hotline:

mailto: hotline-cam@e2v.com



Whilst e2v has taken care to ensure the accuracy of the information contained herein it accepts no responsibility for the consequences of any use thereof and also reserves the right to change the specification of goods without notice. e2v accepts no liability beyond that set out in its standard conditions of sale in respect of infringement of third party patents arising from the use of tubes or other devices in accordance with information contained herein.